



## Double Offset High Performance Butterfly Valve



### **INSTALLATION**

### **OPERATION**

### **MAINTENANCE**

## TABLE OF CONTENTS

<b>INTRODUCTION</b> .....	<b>3</b>
PRODUCT STORAGE.....	3
PRODUCT MARKING.....	3
FIGURE 1. APOLLO® INTERNATIONAL HPBFV I.D. TAG.....	3
FIGURE 2. HOW TO SPECIFY HIGH PERFORMANCE BUTTERFLY VALVES.....	4
TABLE 1. OPERATING PRESSURES.....	4
<b>INSTALLATION INFORMATION</b> .....	<b>5</b>
INSTALLATION INSTRUCTIONS.....	5
FIGURE 3. INSTALLATION DIAGRAM.....	6
TABLE 2. CLASS 150 STUD AND BOLT SPECIFICATIONS.....	7
TABLE 3. CLASS 300 STUD AND BOLT SPECIFICATIONS.....	7
TABLE 4. CLASS 600 STUD AND BOLT SPECIFICATIONS.....	8
FIGURE 4. FLANGE BOLT TIGHTENING SEQUENCE.....	8
<b>ASSEMBLY/DISASSEMBLY INSTRUCTIONS</b> .....	<b>9</b>
MAINTENANCE AND REPAIR.....	9
SOFT/METAL SEATED VALVE DISASSEMBLY.....	9
FIGURE 5. SOFT SEAT DISASSEMBLY DIAGRAM.....	9
SOFT/METAL SEATED RETAINER REPLACEMENT.....	10
FIGURE 6. SOFT SEATED RETAINER REPLACEMENT DIAGRAM.....	10
FIRE SAFE SEATED VALVE DISASSEMBLY AND SEAT RETAINER REPLACEMENT.....	11
FIGURE 7. FIRE SAFE SEATED RETAINER REPLACEMENT DIAGRAM.....	11
TABLE 5. SEAT RETAINER BOLTING TORQUE.....	12
STEM PACKING REPLACEMENT.....	13
FIGURE 8. UPPER STEM PACKING REPLACEMENT.....	13
TABLE 6. GLAND PLATE TORQUE.....	13
END CAP SEAL REPLACEMENT.....	14
FIGURE 9. END CAP SEAL REPLACEMENT.....	14
TABLE 7. END CAP BOLT TORQUE.....	14
LEVER HANDLE MOUNTING PROCEDURE.....	15
GEAR OPERATOR MOUNTING/SETTING PROCEDURE & ILLUSTRATION.....	15
<b>BUTTERFLY VALVE EXPLODED VIEWS</b> .....	<b>16</b>
FIGURE 10. SOFT SEATED EXPLODED VIEW.....	16
FIGURE 11. FIRE SAFE SEATED EXPLODED VIEW.....	17
FIGURE 12. METAL SEATED EXPLODED VIEW.....	18
<b>REPAIR KIT PART NUMBER LIST</b> .....	<b>19</b>
TABLE 8 - 10. REPAIR KIT PART NUMBER LIST.....	19
<b>AMENDMENT REGISTER</b> .....	<b>24</b>

**INTRODUCTION**

**FOR SPECIFIC DESIGN FEATURES FOR HIGH PERFORMANCE BUTTERFLY VALVE SEE CATALOG**

- PRODUCT STORAGE**
- The valves should be stored with the disc in the closed position.
  - The valves should be stored indoors in a clean, dry, well-ventilated place away from corrosive materials and protected from excessive dust and dirt.
  - The valves should be stored on a rack or pallet and arranged to prevent damage during handling.
  - Keep valves in original shipping container with original protection prior to installation.
  - Valves should be protected to prevent damage to the flange faces, disc sealing edge and operator.

**PRODUCT MARKING**

All APOLLO® International High Performance Butterfly Valves are equipped with an identification tag attached to the valve neck (Figure 1). This tag provides the model number, pressure class, size, max pressure rating, and date of manufacture.

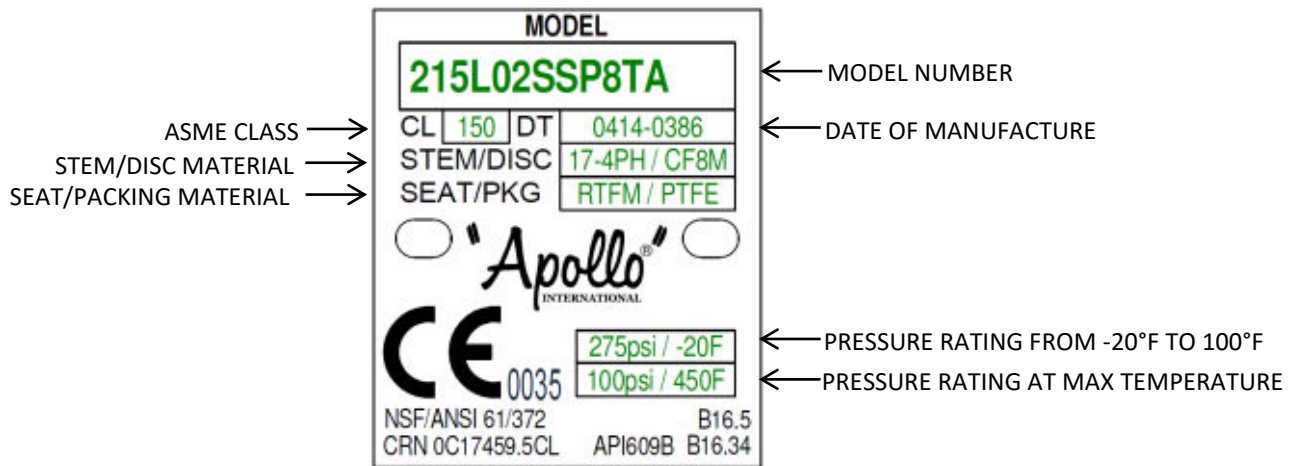

**FIGURE 1. APOLLO® INTERNATIONAL HIGH PERFORMANCE BUTTERFLY VALVE IDENTIFICATION TAG EXAMPLE**

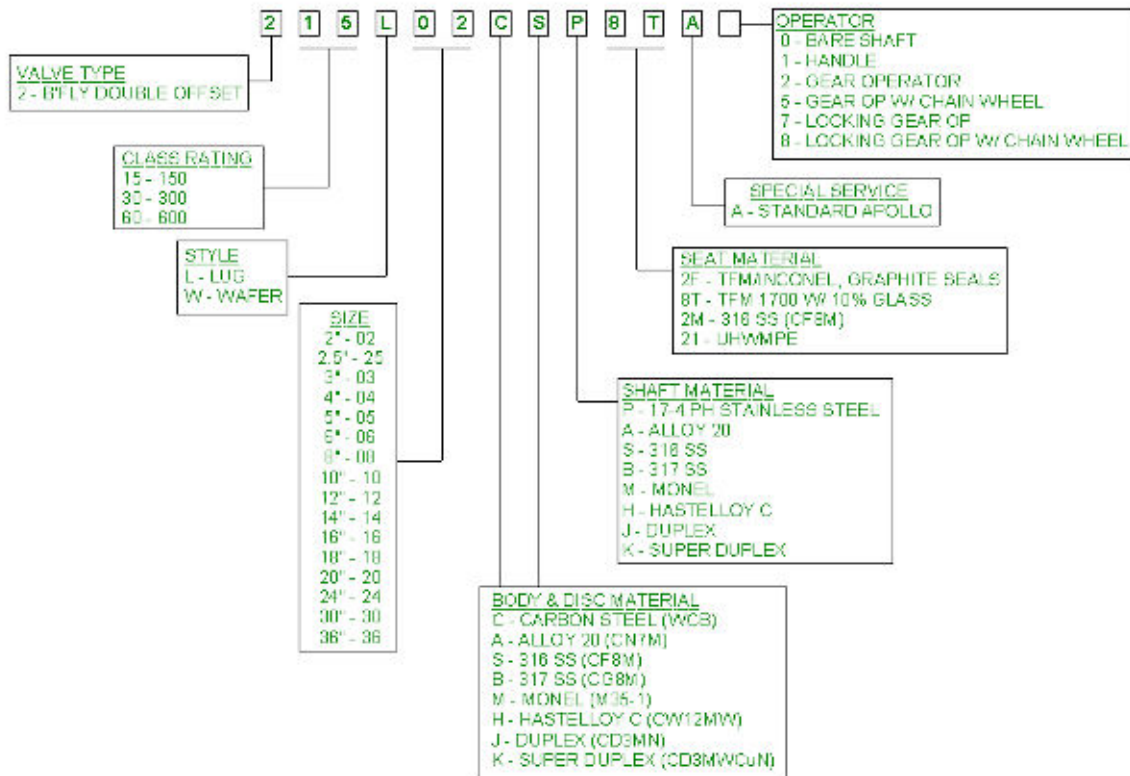

**FIGURE 2. HOW TO SPECIFY HIGH PERFORMANCE, DOUBLE OFFSET, ASME BUTTERFLY VALVE**

**TABLE 1. OPERATING PRESSURES**

Material	Class 150		Class 300		Class 600	
	Imperial	Metric	Imperial	Metric	Imperial	Metric
WCB Carbon Steel	285 PSI @ 100°F	19.6 BAR @ 37°C	740 PSI @ 100°F	51.0 BAR @ 37°C	1480 PSI @ 100°F	102.0 BAR @ 37°C
	100 PSI @ 450°F	6.89 BAR @ 232°C	100 PSI @ 450°F	6.89 BAR @ 232°C	100 PSI @ 450°F	6.89 BAR @ 232°C
316 Stainless Steel	275 PSI @ 100°F	18.9 BAR @ 37°C	720 PSI @ 100°F	49.6 BAR @ 37°C	1440 PSI @ 100°F	99.2 BAR @ 37°C
	100 PSI @ 450°F	6.89 BAR @ 232°C	100 PSI @ 450°F	6.89 BAR @ 232°C	100 PSI @ 450°F	6.89 BAR @ 232°C
317 Stainless Steel	275 PSI @ 100°F	18.9 BAR @ 37°C	720 PSI @ 100°F	49.6 BAR @ 37°C	1440 PSI @ 100°F	99.2 BAR @ 37°C
	100 PSI @ 450°F	6.89 BAR @ 232°C	100 PSI @ 450°F	6.89 BAR @ 232°C	100 PSI @ 450°F	6.89 BAR @ 232°C
Alloy 20	230 PSI @ 100°F	15.8 BAR @ 37°C	600 PSI @ 100°F	41.3 BAR @ 37°C	1200 PSI @ 100°F	82.7 BAR @ 37°C
	100 PSI @ 450°F	6.89 BAR @ 232°C	100 PSI @ 450°F	6.89 BAR @ 232°C	100 PSI @ 450°F	6.89 BAR @ 232°C
Monel	230 PSI @ 100°F	15.8 BAR @ 37°C	600 PSI @ 100°F	41.3 BAR @ 37°C	1200 PSI @ 100°F	82.7 BAR @ 37°C
	100 PSI @ 450°F	6.89 BAR @ 232°C	100 PSI @ 450°F	6.89 BAR @ 232°C	100 PSI @ 450°F	6.89 BAR @ 232°C
Hastelloy C	230 PSI @ 100°F	15.8 BAR @ 37°C	600 PSI @ 100°F	41.3 BAR @ 37°C	1200 PSI @ 100°F	82.7 BAR @ 37°C
	100 PSI @ 450°F	6.89 BAR @ 232°C	100 PSI @ 450°F	6.89 BAR @ 232°C	100 PSI @ 450°F	6.89 BAR @ 232°C
Duplex	290 PSI @ 100°F	19.9 BAR @ 37°C	750 PSI @ 100°F	51.7 BAR @ 37°C	1500 PSI @ 100°F	103.4 BAR @ 37°C
	100 PSI @ 450°F	6.89 BAR @ 232°C	100 PSI @ 450°F	6.89 BAR @ 232°C	100 PSI @ 450°F	6.89 BAR @ 232°C
Super Duplex	290 PSI @ 100°F	19.9 BAR @ 37°C	750 PSI @ 100°F	51.7 BAR @ 37°C	1500 PSI @ 100°F	103.4 BAR @ 37°C
	100 PSI @ 450°F	6.89 BAR @ 232°C	100 PSI @ 450°F	6.89 BAR @ 232°C	100 PSI @ 450°F	6.89 BAR @ 232°C



**Warning! – APOLLO<sup>®</sup> International High Performance Butterfly valves should never be installed where service conditions could exceed the valve ratings. Failure to heed warning may result in personal injury and/or property damage.**



### **INSTALLATION INFORMATION**

**Flange gaskets used with APOLLO<sup>®</sup> International High Performance Butterfly valves can be standard fiber gaskets (such as non-asbestos, flexible graphite, or equivalent gasket materials) that meet dimensional requirements of ASME B16.21. Thick elastomeric gaskets are not recommended. Metallic spiral wound gaskets that meet ASME B16.20 may also be used.**

### **INSTALLATION INSTRUCTIONS**

1. Refer to Figure 3 prior to installation for diagram.
2. Check to make sure that the pipe flange and valve sealing faces are clean and free from any debris (pipe scale, weld slag, etc.).
3. Check the valve nameplate to ensure that the pressure and valve materials are correct for the application. See Table 1 for operating pressures and temperatures.



**Warning! – APOLLO<sup>®</sup> International High Performance Butterfly valves should never be installed where service conditions could exceed the valve ratings. Failure to heed warning may result in personal injury and/or property damage.**

4. To prevent damage to the disc sealing edge during installation, position the disc in the “closed” position. Check the tightness of all the valve’s bolts and nuts before installation begins. Do not over tighten the packing gland.
5. Spread the pipe flanges apart allowing the valve to be slipped easily in between the flanges.
6. Center the valve and flange gaskets between the flanges and loosely install all the flange bolts. On the wafer valve, the flange bolts that pass through the alignment lugs should be installed first. Consult Table 2, 3, and 4 for correct flange bolt size and quantity.
7. Slowly move the valve to the “full open” position and back to the closed position ensuring that the disc moves freely without any obstruction. If no obstruction is encountered, return the valve to the full open position and hand tighten all flange bolts using the bolt tightening sequence shown in Figure 4.
8. Rotate the disc from the full open position to the full closed position and make sure that the valve is properly centered and the disc edge does not contact the pipe I.D. Return the disc to the full open position and tighten the flange bolts incrementally following the bolt tightening sequence and suggested torque values provided in Tables 2, 3 and 4. After all flange bolts are fully tightened, cycle the valve from full open to full closed to ensure there is proper disc clearance.

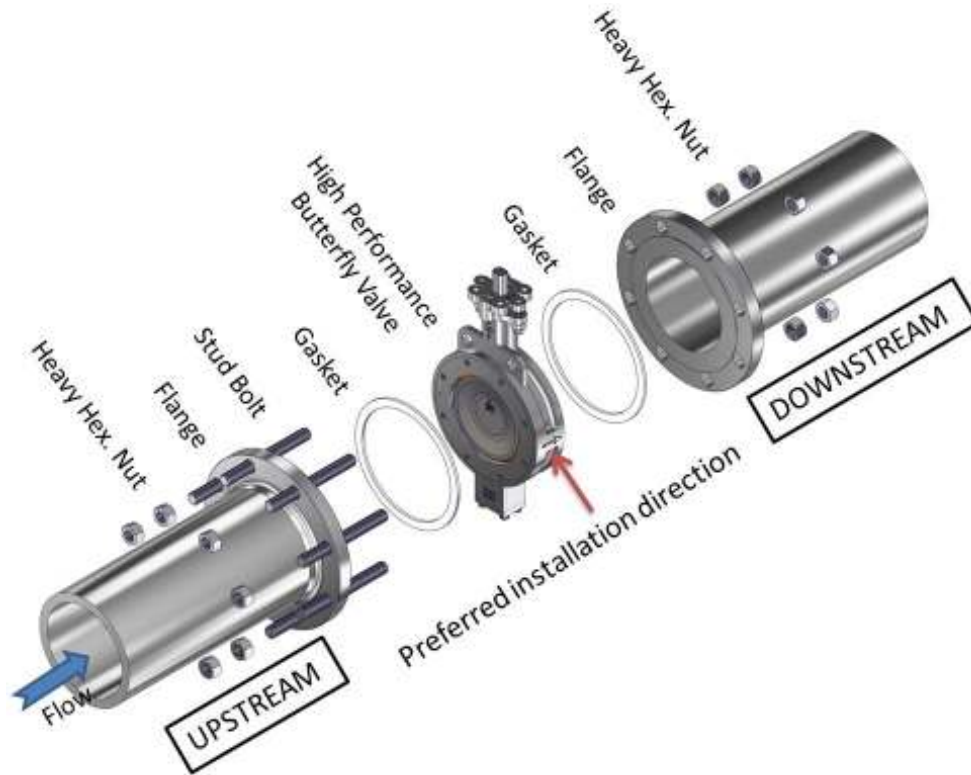

**Preferred installation direction is flow into the disc's face.  
See arrow on side of valve for preferred flow direction.**

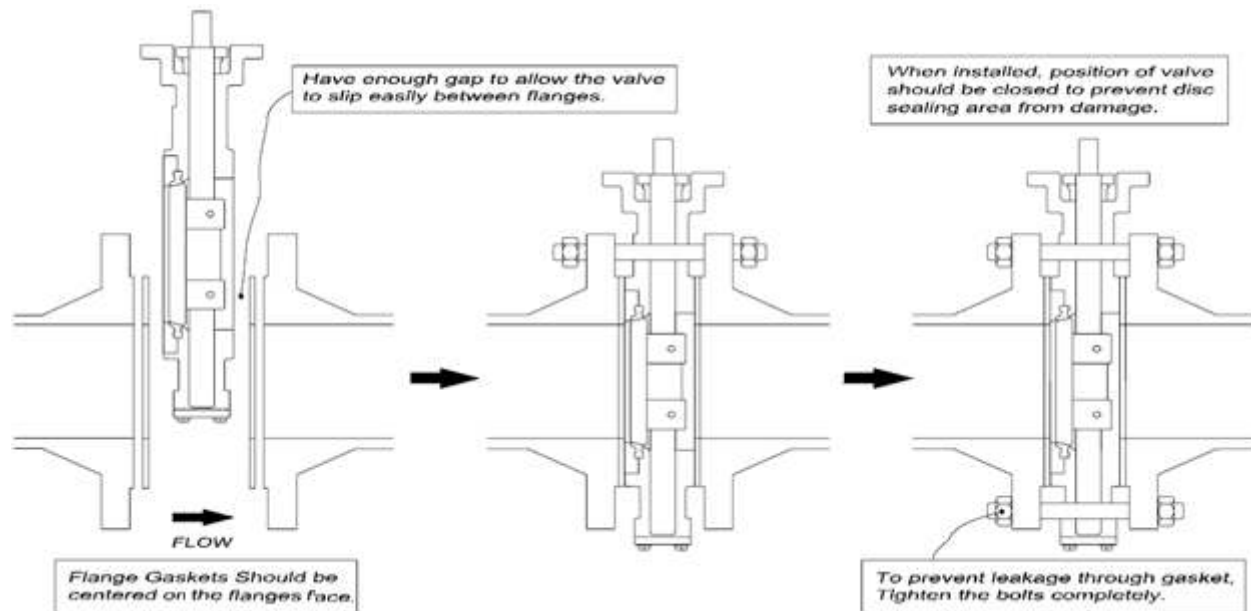

**FIGURE 3. INSTALLATION DIAGRAM**

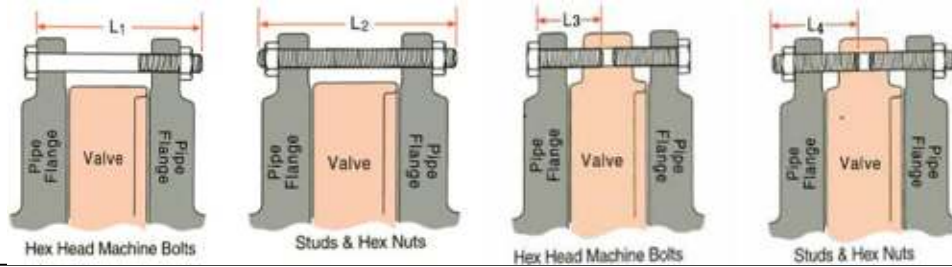

**TABLE 2. CLASS 150 STUD & BOLT SPECIFICATIONS**

Valve size		Diameter	TPI	Wafer Stud Min.Length		Quantity	Lug Bolt Length		Quantity
(in)	(dn)	(in)		(in)	(in)	(total)	(in)	(in)	(total)
2	50	5/8"	11UNC-2B	4.50 (L1)	5.25 (L2)	4	2.00 (L3)	2.75 (L4)	8
2.5	65	5/8"	11UNC-2B	5.00 (L1)	5.75 (L2)	4	2.00 (L3)	3.00 (L4)	8
3	80	5/8"	11UNC-2B	5.25 (L1)	6.00 (L2)	4	2.25 (L3)	3.00 (L4)	8
4	100	5/8"	11UNC-2B	5.50 (L1)	6.25 (L2)	8	2.25 (L3)	3.00 (L4)	16
5	125	3/4"	10UNC-2B	5.75 (L1)	6.50 (L2)	8	2.25 (L3)	3.25 (L4)	16
6	150	3/4"	10UNC-2B	5.75 (L1)	6.75 (L2)	8	2.50 (L3)	3.25 (L4)	16
8	200	3/4"	10UNC-2B	6.25 (L1)	7.25 (L2)	8	2.50 (L3)	3.50 (L4)	16
10	250	7/8"	9UNC-2B	7.00 (L1)	8.00 (L2)	12	2.75 (L3)	3.75 (L4)	24
12	300	7/8"	9UNC-2B	7.50 (L1)	8.50 (L2)	12	2.75 (L3)	3.75 (L4)	24
14	350	1"	8UNC-2B	8.50 (L1)	9.50 (L2)	12	3.00 (L3)	4.25 (L4)	24
16	400	1"	8UNC-2B	9.00 (L1)	10.00 (L2)	16	3.25 (L3)	4.25 (L4)	32
18	450	1-1/8"	8UN-2B	10.00 (L1)	11.00 (L2)	16	3.50 (L3)	4.75 (L4)	32
20	500	1-1/8"	8UN-2B	10.50 (L1)	11.75 (L2)	16	3.50 (L3)	4.75 (L4)	32
				3.25 (L3)	4.50 (L4)	8	3.25 (L3)	4.5 (L4)	8
24	600	1-1/4"	8UN-2B	12.25 (L1)	13.50 (L2)	16	4.00 (L3)	5.25 (L4)	32
				3.50 (L3)	5.00 (L4)	8	3.50 (L3)	5.00 (L4)	8
30	750	1-1/4"	8UN-2B	15.75 (L1)	17.00 (L2)	24	5.00 (L3)	6.50 (L4)	48
				4.75 (L3)	6.25 (L4)	8	4.75 (L3)	6.25 (L4)	8
36	900	1-1/2"	8UN-2B	17.75 (L1)	19.5 (L2)	28	6.00 (L3)	7.50 (L4)	56
				5.75 (L3)	7.25 (L4)	8	5.75 (L3)	7.25 (L4)	8

**TABLE 3. CLASS 300 STUD & BOLT SPECIFICATIONS**

Valve size		Diameter	TPI	Wafer Stud Min.Length		Quantity	Lug Bolt Length		Quantity
(in)	(dn)	(in)		(in)	(in)	(total)	(in)	(in)	(total)
2	50	5/8"	11UNC-2B	4.75 (L1)	5.50 (L2)	8	2.00 (L3)	2.75 (L4)	16
2.5	65	3/4"	10UNC-2B	5.50 (L1)	6.25 (L2)	8	2.50 (L3)	3.25 (L4)	16
3	80	3/4"	10UNC-2B	5.75 (L1)	6.50 (L2)	8	2.50 (L3)	3.25 (L4)	16
4	100	3/4"	10UNC-2B	6.25 (L1)	7.00 (L2)	8	2.75 (L3)	3.50 (L4)	16
5	125	3/4"	10UNC-2B	6.50 (L1)	7.50 (L2)	8	2.75 (L3)	3.50 (L4)	16
6	150	3/4"	10UNC-2B	6.75 (L1)	7.75 (L2)	12	2.75 (L3)	3.75 (L4)	24
8	200	7/8"	9UNC-2B	8.00 (L1)	9.00 (L2)	12	3.25 (L3)	4.25 (L4)	24
10	250	1"	8UNC-2B	9.00 (L1)	10.25 (L2)	12	3.75 (L3)	4.75 (L4)	32
				3.75 (L3)	4.75 (L4)	8			
12	300	1-1/8"	8UN-2B	9.75 (L1)	11.00 (L2)	12	4.00 (L3)	5.00 (L4)	32
				4.00 (L3)	5.00 (L4)	8			
14	350	1-1/8"	8UN-2B	11.00 (L1)	12.25 (L2)	16	4.00 (L3)	5.25 (L4)	32
				3.50 (L3)	5.00 (L4)	8			
16	400	1-1/4"	8UN-2B	12.00 (L1)	13.50 (L2)	16	4.25 (L3)	5.50 (L4)	32
				3.85 (L3)	5.25 (L4)	8			
18	450	1-1/4"	8UN-2B	13.00 (L1)	14.25 (L2)	20	4.50 (L3)	5.75 (L4)	40
				4.00 (L3)	5.50 (L4)	8			
20	500	1-1/4"	8UN-2B	13.50 (L1)	15.00 (L2)	20	4.50 (L3)	6.00 (L4)	40
				4.10 (L3)	5.50 (L4)	8			
24	600	1-1/2"	8UN-2B	15.50 (L1)	17.00 (L2)	20	5.25 (L3)	6.75 (L4)	40
				4.50 (L3)	6.25 (L4)	8			



**TABLE 4. CLASS 600 STUD & BOLT SPECIFICATIONS**

Valve size		Diameter		TPI	Wafer Stud Min.Lenth		Quantity	Lug Bolt Length		Quantity
(in)	(dn)	(in)			(in)	(in)	(total)	(in)	(in)	(total)
3	80	3/4"	10UNC-2B	6.75 (L1)	7.50 (L2)	8	3.00 (L3)	3.75 (L4)	16	
4	100	7/8"	9UNC-2B	7.75 (L1)	9.00 (L2)	8	3.25 (L3)	4.25 (L4)	16	
6	150	1"	8UNC-2B	9.25 (L1)	10.50 (L2)	8	3.75 (L3)	5.00 (L4)	24	
				3.75 (L3)	5.00 (L4)	8				
8	200	1-1/8"	8UN-2B	11.25 (L1)	12.25 (L2)	8	4.25 (L3)	5.50 (L4)	24	
				4.25 (L3)	5.50 (L4)	8				
10	250	1-1/8"	8UN-2B	12.25 (L1)	13.50 (L2)	12	4.75 (L3)	6.00 (L4)	24	
				4.25 (L3)	5.75 (L4)	8	4.25 (L3)	5.75 (L4)	8	
12	300	1-1/4"	8UN-2B	13.50 (L1)	15.00 (L2)	16	5.00 (L3)	6.25 (L4)	32	
				4.40 (L3)	6.00 (L4)	8	4.40 (L3)	6.00 (L4)	8	

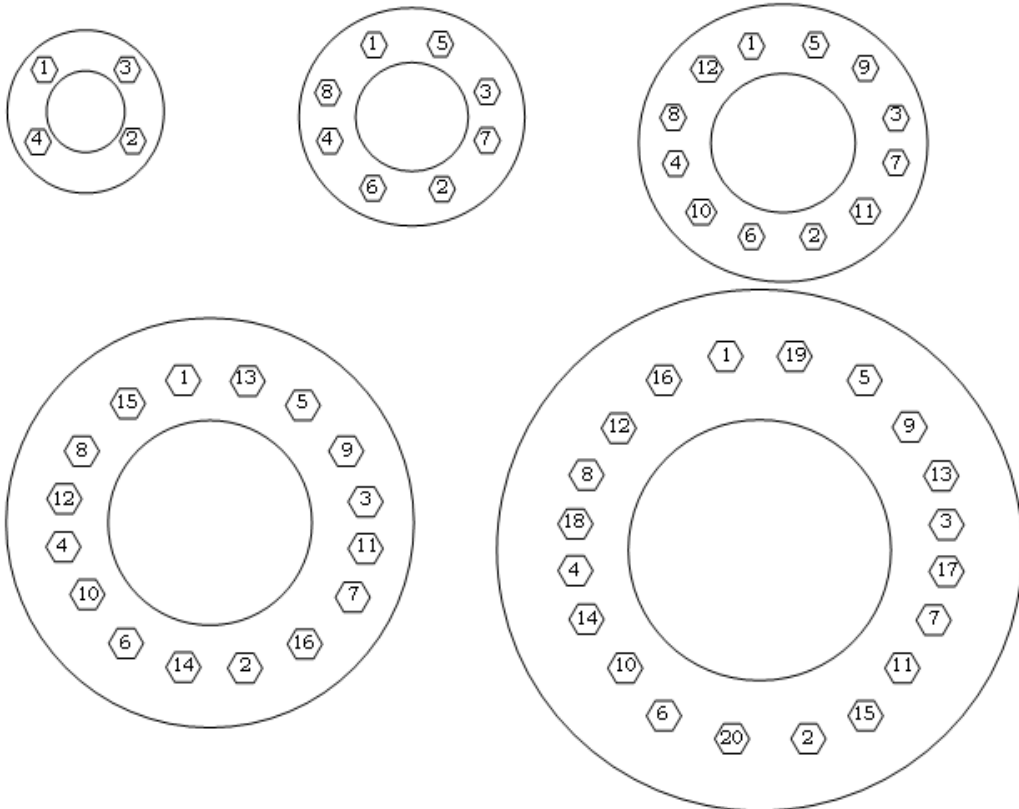

**FIGURE 4. FLANGE BOLT TIGHTENING SEQUENCE**



## **ASSEMBLY/DISASSEMBLY INSTRUCTIONS**

### **MAINTENANCE AND REPAIR**

APOLLO® International High Performance Butterfly valves are designed for extended service with minimal wear and servicing. No regular lubrication is required. Prior to any repair or replacement, the valve must be removed from the line following these precautions:

1. The pipeline on both side of the valve must be depressurized and drained.
2. Ensure that the disc is in the full closed position before removing the valve from the line
3. **DO NOT** remove an actuator or operator from the valve while the line is still pressurized.
4. If stem leakage is observed through the packing box, tighten the gland nuts.



**Note: do not over-tighten packing box gland nuts. Over-tightening will increase the torque required to operate the valve. When tightening the gland nuts, use half-turn increments until leakage has stopped.**

### **SOFT/METAL SEATED VALVE DISASSEMBLY**

1. Refer to Figure 5 for soft seat disassembly.
2. Open valve disc to 10-15 degrees with operator or lever.
3. Remove all bolts on the seat retainer. Using the seat retainer bolts, insert them into the smaller tapped holes (Jacking taps). Remove the seat retainer taking care not to scratch or damage the sealing surfaces.

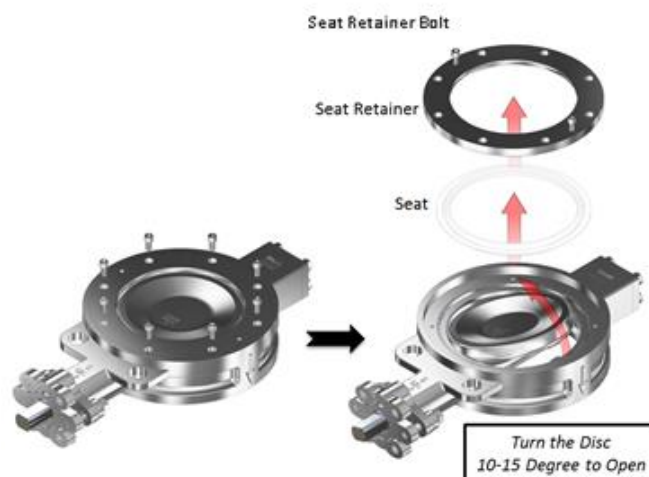

**FIGURE 5. SOFT/METAL SEATED DISASSEMBLY DIAGRAM**

**SOFT/METAL SEATED RETAINER REPLACEMENT**

1. Refer to Figure 6 for soft seated retainer replacement.
2. Using a clean cloth, wipe the seat assembly. Inspect seat and disc for scratches or damage on the disc sealing surface.
3. Install the new seat and reassemble the seat retainer by slightly tightening the retainer bolts and closing the valve.
4. Using the operating device, open and close the valve disc at least 3 times to adjust the seat and seat retainer to the proper position. Open the valve disc to 10-15 degrees and fully tighten the seat retainer bolts to the applicable torque specified in Table 5.
5. Valve is now ready to be reinstalled.

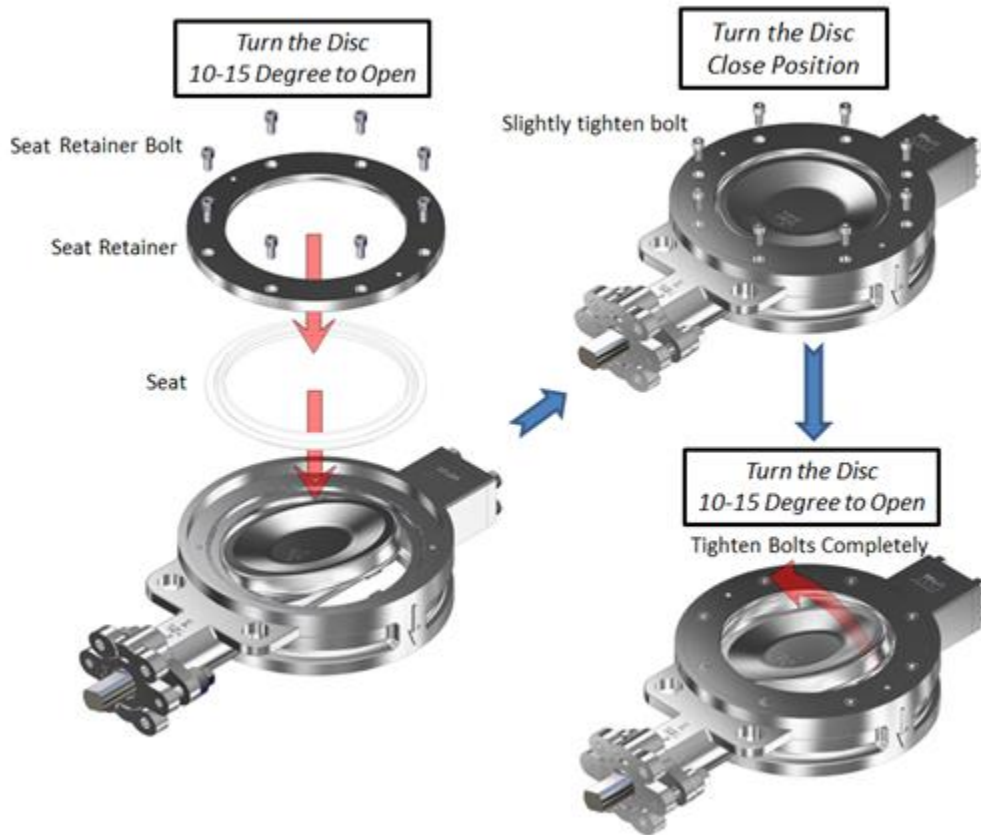

**FIGURE 6. SOFT/METAL SEATED RETAINER REPLACEMENT**

**FIRE SAFE SEATED VALVE DISASSEMBLY AND SEAT RING REPLACEMENT**

1. Refer to Figure 7 for fire safe seat replacement.
2. Open valve disc to 10-15 degrees with operator or lever.
3. Remove all bolts on the seat retainer. Using the seat retainer bolts, insert them into the smaller tapped holes (Jacking taps). Remove the seat ring, metal seal, and body seal, taking care not to scratch or damage the seat.
4. Using a clean cloth, wipe the seat assembly. Inspect seat and disc for scratches or damage on the disc sealing surface.
5. Install the new seat, metal seal, and body seal. Then reassemble the seat retainer by slightly tightening the seat retainer bolts and closing the valve.
6. Using the operating device, open and close the valve disc at least 3 times to adjust the seat and seat retainer to the proper position. Open the valve disc to 10-15 degrees and fully tighten the seat retainer bolts to the applicable torque specified in Table 5.
7. Valve is now ready to be reinstalled.

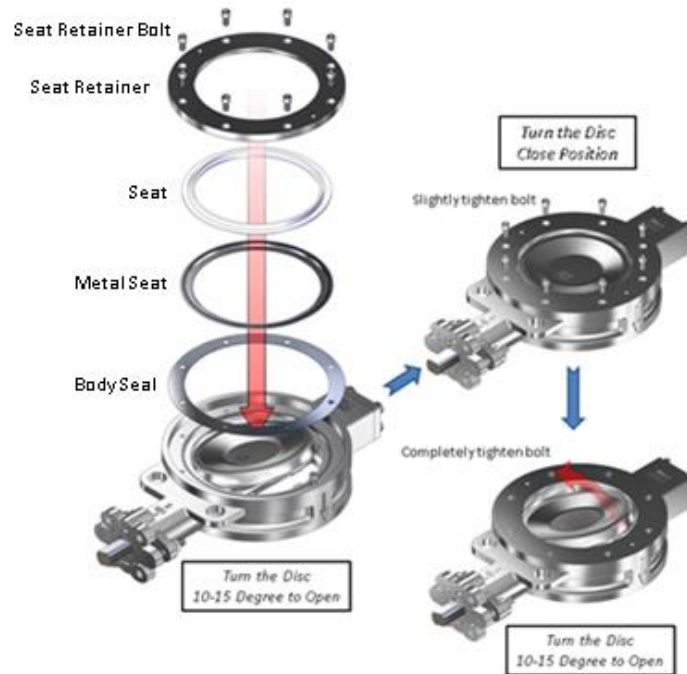

**FIGURE 7. FIRE SAFE SEATED RETAINER REPLACEMENT DIAGRAM**

**TABLE 5. SEAT RETAINER BOLTING TORQUE**

<b>CLASS 150 SEAT RETAINER BOLTING TORQUE</b>			
<b>SIZE</b>		<b>TORQUE</b>	
<b>VALVE</b>	<b>BOLT</b>	<b>MIN (IN-LBS)</b>	<b>MAX (IN-LBS)</b>
2" - 4"	10-24UNC	30	45
6" - 10"	1/4-20UNC	80	105
12" - 18"	5/16-18UNC	160	200
20" - 36"	3/8-16UNC	285	395

<b>CLASS 300 SEAT RETAINER BOLTING TORQUE</b>			
<b>SIZE</b>		<b>TORQUE</b>	
<b>VALVE</b>	<b>BOLT</b>	<b>MIN (IN-LBS)</b>	<b>MAX (IN-LBS)</b>
2" - 3"	10-24UNC	30	45
4" - 8"	1/4-20UNC	80	105
10" - 16"	5/16-18UNC	160	200
18" - 20"	3/8-16UNC	285	395
24"	1/2-13UNC	535	705

<b>CLASS 600 SEAT RETAINER BOLTING TORQUE</b>			
<b>SIZE</b>		<b>TORQUE</b>	
<b>VALVE</b>	<b>BOLT</b>	<b>MIN (IN-LBS)</b>	<b>MAX (IN-LBS)</b>
3" - 4"	1/4-20UNC	30	45
6"	5/16-18UNC	80	105
8" - 10"	3/8-16UNC	160	200
12"	1/2-13UNC	285	395

**STEM PACKING REPLACEMENT**

1. Refer to Figure 8 for upper stem packing replacement.
2. Loosen gland plate nut and remove gland plate, then gently lift and remove packing gland. Using a tool such as a screw driver or pick, begin removing packing. Be careful not to damage or scratch the stem or stuffing box walls.
3. After carefully removing used packing, carefully clean the stuffing box and discard all used packing. Once clean, insert a new set of packing into the stuffing box.
4. Once new packing is installed, reassemble the packing gland and gland plate. Assemble the disc spring retainer, disc spring, washers, and nuts. Tighten the gland plate nuts sufficiently. Be careful not to over tighten. It may increase operating torque and decrease the life of the packing. Refer to Table 6 for recommended torque.



**FIGURE 8. UPPER STEM PACKING REPLACEMENT**

CLASS 150		
SIZE	HEX NUT	TORQUE (IN-LBS)
2"-4"	5/16-18UNC	115
5"-6"	3/8-16UNC	133
8"-12"	1/2-13UNC	266
14"	5/8-11UNC	284
16"-20"	3/4-10UNC	354
24"-36"	7/8-9UNC	388

CLASS 300		
SIZE	HEX NUT	TORQUE (IN-LBS)
2"-4"	5/16-18UNC	115
5"-6"	3/8-16UNC	222
8"-10"	1/2-13UNC	292
12"	5/8-11UNC	328
14"-18"	3/4-10UNC	399
20"-24"	7/8-9UNC	461

CLASS 150		
SIZE	HEX NUT	TORQUE (IN-LBS)
3"-4"	3/8-16UNC	177
6"	1/2-13UNC	284
8"-10"	5/8-11UNC	337
12"	3/4-10UNC	372

**TABLE 6. GLAND PLATE TORQUE**

**END CAP SEAL REPLACEMENT**

1. Refer to Figure 9 for end cap seal and spacer replacement.
2. Remove bolts and end cap from the bottom of the valve. Using a tool such as a screw driver or pick, begin removing packing. Be careful not to damage or scratch the stem or stuffing box walls. Then remove the spacer from the end cap.
3. After carefully removing used packing, carefully clean the stuffing box and discard all used packing. Once clean, insert a new set of packing into the stuffing box and a new spacer in the end cap.
4. Once new packing is installed, reassemble the end cap, spring washers and tighten the end cap bolts to the correct torque value listed in Table 7.
5. Valve is now ready to be reinstalled.

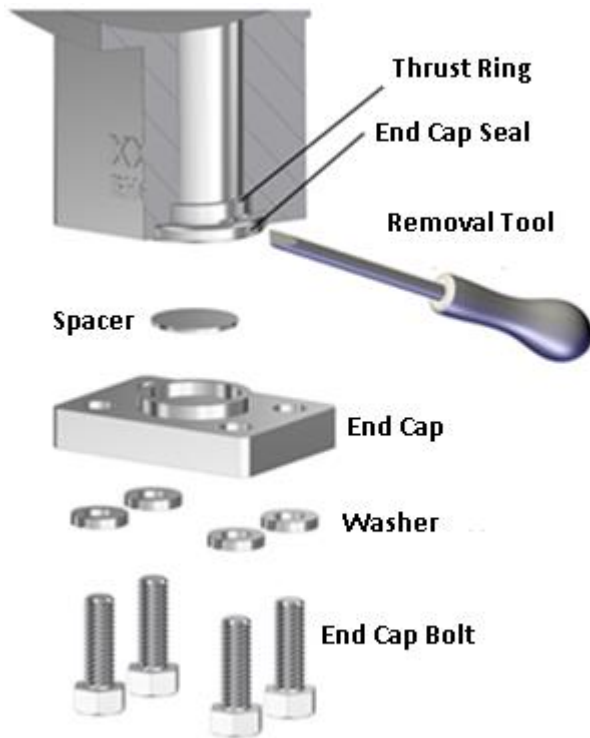

**FIGURE 9. END CAP SEAL REPLACEMENT**

CLASS 150		
SIZE	HEX SCREW	TORQUE (IN-LBS)
2"-4"	1/4-20UNC	115
5"-10"	5/16-18UNC	230
12"-14"	3/8-16UNC	354
16"-36"	1/2-13UNC	753

CLASS 300		
SIZE	HEX SCREW	TORQUE (IN-LBS)
2"-4"	1/4-20UNC	115
5"-8"	5/16-18UNC	230
10"-12"	3/8-16UNC	399
14"-24"	1/2-13UNC	957

CLASS 600		
SIZE	HEX SCREW	TORQUE (IN-LBS)
3"-4"	3/8-16UNC	115
6"	1/2-13UNC	230
8"-10"	5/8-11UNC	354
12"	3/4-10UNC	753

**TABLE 7. END CAP BOLT TORQUE**

**LEVER MOUNTING PROCEDURE**

1. Start by loosely assembling the notch plate on the valve top plate. The notch plate should be installed with the notches in the third quadrant of the valve top plate with the stop tabs at the 6 o'clock and 9 o'clock position. The notch plate should be installed with the stop tabs pointing downwards.
2. Next, install the lever so that the lever fully engages in the notches when the lever is released and tighten the notch plate screws
3. Compress the lever and position the disc so that the valve is in the full closed position. Align the last notch on the notch plate at the 9 o'clock position with the lever and tighten the notch plate screws.
4. Compress the lever and position the disc so that the valve is in the full open position and release the lever. The lever should line-up with the last notch on the notch plate at the 6 o'clock position.

**GEAR OPERATOR MOUNTING/SETTING PROCEDURE**

**(Refer to Illustration 1)**

1. Mount gear operator (Item 1) on top of butterfly valve with bolts and washers provided with each assembly.
2. Loosen the stop screws and locking nuts (Item 2, 3 & 4) approximately three to four turns on both sides of the gear operator.
3. Rotate hand wheel to the full open position and tighten the "open" stop screw (Item 4). Now tighten the locking nut (Item 2).
4. Rotate hand wheel to the full closed position and tighten the "Closed" stop screw (Item 3). Now tighten the locking nut (Item 2).
5. Open disc to 20% then back to closed position. Re-adjust stop screw and nut (Item 3) if necessary. You have now properly adjusted both the "Open" and "Closed" stop positions.

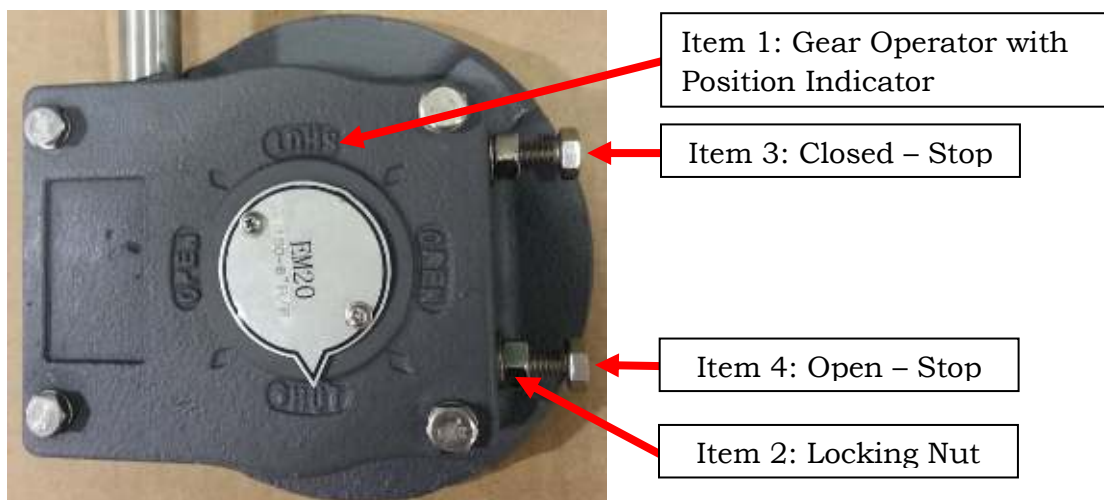



**HIGH PERFORMANCE BUTTERFLY VALVE EXPLODED VIEWS**

#	PART	MATERIAL
1	Body	A351-CF8M or A216-WCB
2	Disc	A351-CF8M
3	Seat	Glass Filled TFM 1700
4	Seat Retainer	A351-CF8M or A216-WCB
5	Seat Retainer Bolts	Stainless Steel 316
6	Stem	17-4PH
7	Disc Pin	17-4PH
8	End Cap Bolt	Stainless Steel 316
9	Washer	Stainless Steel 316
10	End Cap	A351-CF8M or A216-WCB
11	Spacer	PTFE
12	End Cap Seal	PTFE
13	Thrust Ring	Stainless Steel 316
14	Lower Bearing	Stainless Steel 316 / PTFE
15	Upper Bearing	Stainless Steel 316 / PTFE
16	Anti-Extrusion Ring	Stainless Steel 316
17	Stem Packing	PTFE
18	Packing Gland	Stainless Steel 316
19	Gland Nut	Stainless Steel 316
20	Washer	Stainless Steel 316
21	Disc Spring	Stainless Steel 304
22	Disc Spring Retainer	Stainless Steel 316
23	Gland Studs	Stainless Steel 316
24	Gland Plate	A351-CF8M or A216-WCB

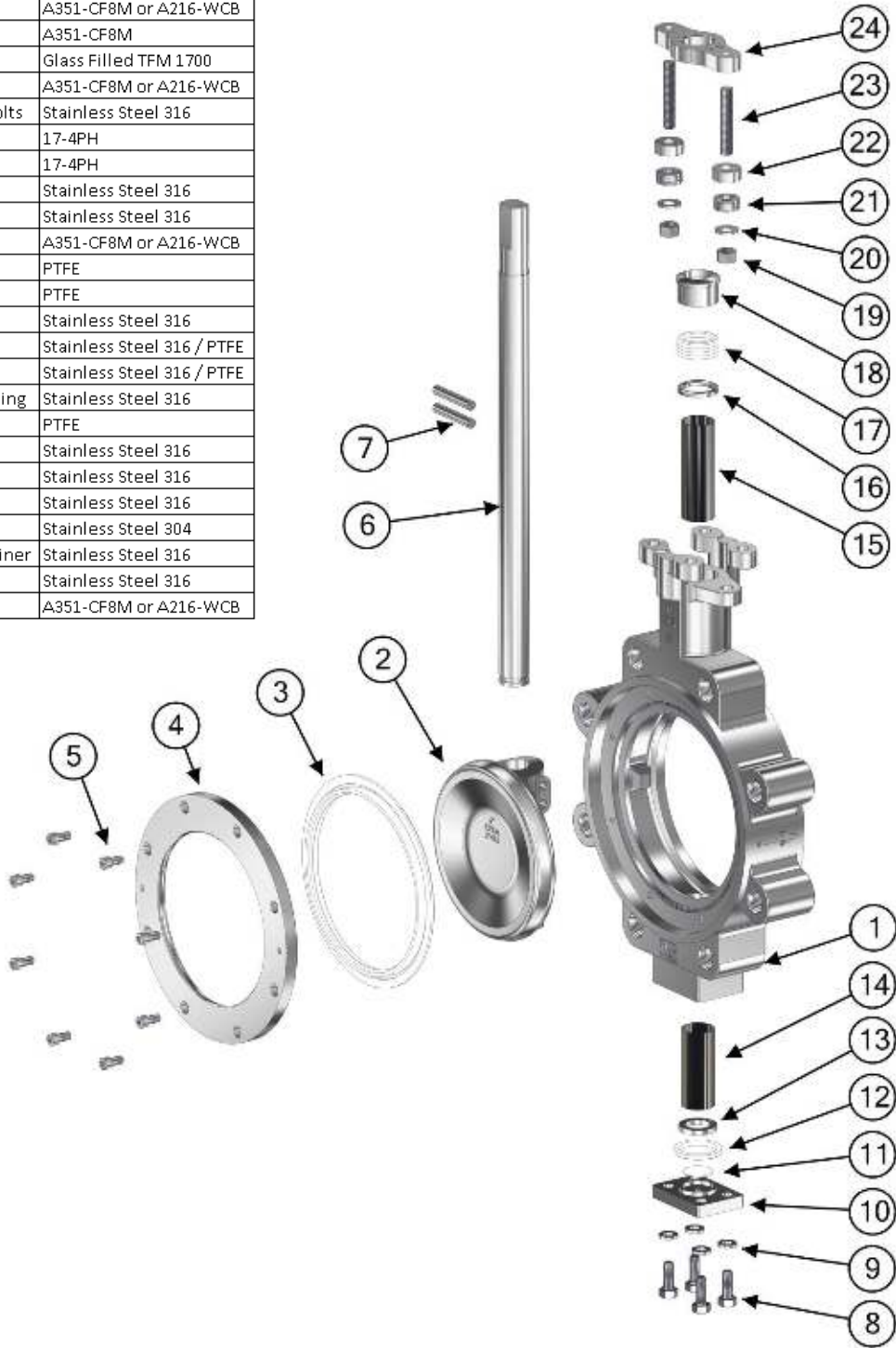

**FIGURE 10. SOFT SEATED EXPLODED VIEW**

#	PART	MATERIAL
1	Body	A351-CF8M or A216-WCB
2	Disc	A351-CF8M
3	Body Seal	Graphite
4	Metal Seat	Inconel 718
5	Resilient Seat	Glass Filled TFM 1700
6	Seat Retainer	A351-CF8M or A216-WCB
7	Seat Retainer Bolts	Stainless Steel 316
8	Stem	17-4PH
9	Disc Pin	17-4PH
10	End Cap Bolt	Stainless Steel 316
11	Washer	Stainless Steel 316
12	End Cap	A351-CF8M or A216-WCB
13	Spacer	Graphite
14	Thrust Seal	Graphite
15	Thrust Ring	Stainless Steel 316
16	Lower Bearing	Stainless Steel 316 / PTFE
17	Upper Bearing	Stainless Steel 316 / PTFE
18	Anti-Extrusion Ring	Stainless Steel 316
19	Stem Packing	Graphite
20	Packing Gland	Stainless Steel 316
21	Gland Nut	Stainless Steel 316
22	Washer	Stainless Steel 316
23	Disc Spring	Stainless Steel 316
24	Disc Spring Retainer	Stainless Steel 316
25	Gland Studs	Stainless Steel 316
26	Gland Plate	A351-CF8M or A216-WCB

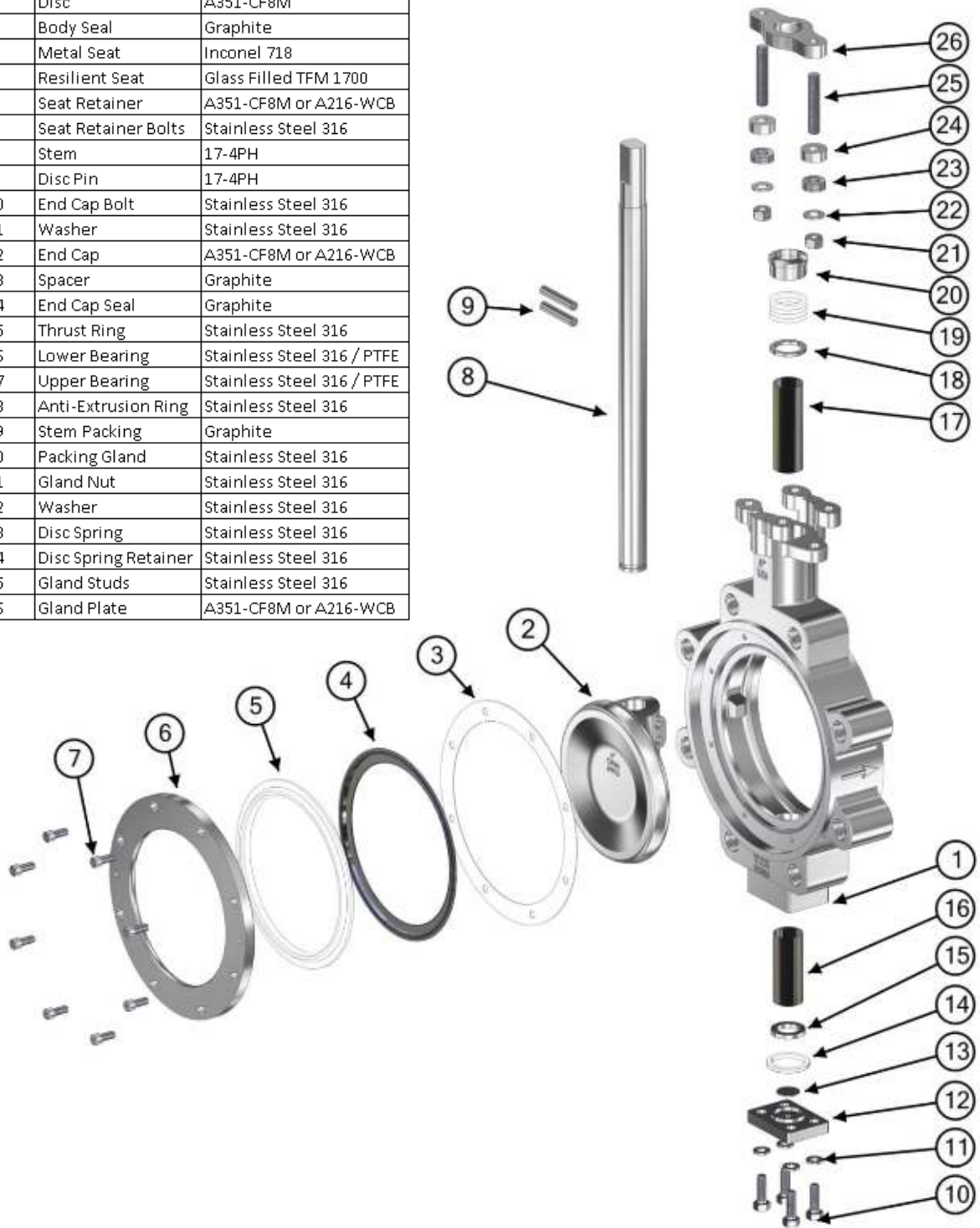

**FIGURE 11. FIRE SAFE SEATED EXPLODED VIEW**

#	PART	MATERIAL
1	Body	A351-CF8M or A216-WCB
2	Disc	A351-CF8M - Nitrided
3	Body Seal	Synthetic Gasket
4	Seat	Stainless Steel 316 - Nitrided
5	Seat Retainer	A351-CF8M or A216-WCB
6	Stem	17-4 PH
7	Disc Pin	17-4 PH
8	End Cap Bolt	Stainless Steel 316
9	Washer	Stainless Steel 316
10	End Cap	A351-CF8M or A216-WCB
11	Spacer	Graphite
12	End Cap Seal	Graphite
13	Thrust Ring	Stainless Steel 316
14	Lower Bearing	Stainless Steel 316 / PTFE
15	Upper Bearing	Stainless Steel 316 / PTFE
16	Anti-Extrusion Ring	Stainless Steel
17	Stem Packing	Graphite
18	Packing Gland	Stainless Steel 316
19	Gland Nut	Stainless Steel 316
20	Washer	Stainless Steel 316
21	Disc Spring	Stainless Steel 304
22	Disc Spring Retainer	Stainless Steel 316
23	Gland Studs	Stainless Steel 316
24	Gland Plate	A351-CF8M or A216-WCB

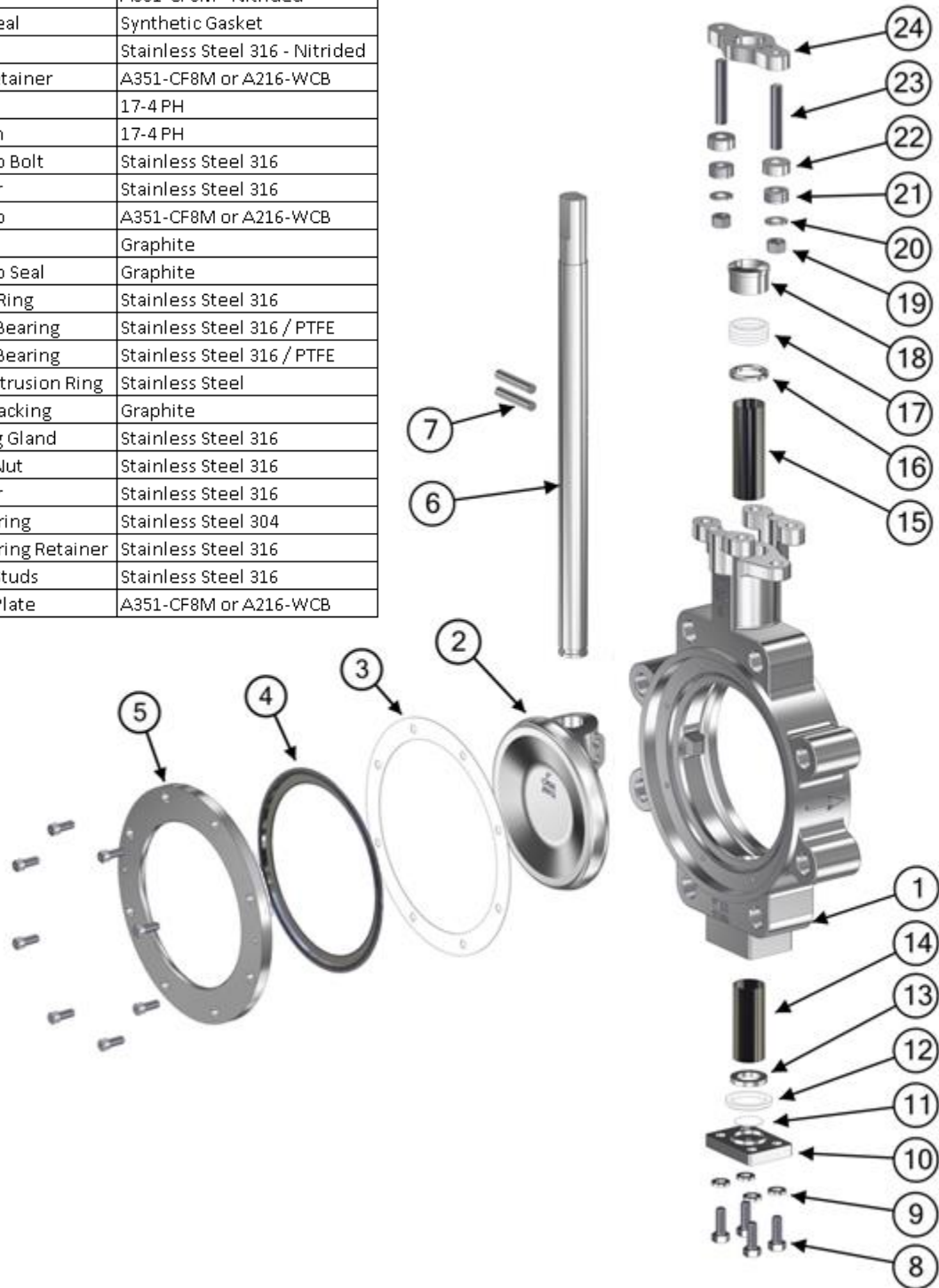

**FIGURE 12. METAL SEATED EXPLODED VIEW**

**TABLE 8. SOFT SEATED REPAIR KIT PART NUMBER LIST**

ANSI Class	Valve Type	Valve Size	RTFM Repair Kit P/N	UHMWPE Repair Kit P/N
150/300	Lug/Wafer	2"	215028TRK	2150221RK
150/300		2.5"	215258TRK	2152521RK
150/300		3"	215038TRK	2150321RK
150/300		4"	215048TRK	2150421RK
150/300		5"	215058TRK	2150521RK
150		6"	215068TRK	2150621RK
150		8"	215088TRK	2150821RK
150		10"	215108TRK	2151021RK
150		12"	215128TRK	2151221RK
150		14"	215148TRK	2151421RK
150		16"	215168TRK	2151621RK
150		18"	215188TRK	2151821RK
150		20"	215208TRK	2152021RK
150		24"	215248TRK	2152421RK
150		30"	215308TRK	2153021RK
150		36"	215368TRK	2153621RK

ANSI Class	Valve Type	Valve Size	RTFM Repair Kit P/N	UHMWPE Repair Kit P/N
300	Lug/Wafer	6"	230068TRK	2300621RK
300		8"	230088TRK	2300821RK
300		10"	230108TRK	2301021RK
300		12"	230128TRK	2301221RK
300		14"	230148TRK	2301421RK
300		16"	230168TRK	2301621RK
300		18"	230188TRK	2301821RK
300		20"	230208TRK	2302021RK
300		24"	230248TRK	2302421RK

\*Class 300, 2"-5" valves use Class 150 repair kits.

ANSI Class	Valve Type	Valve Size	RTFM Repair Kit P/N
600	Lug/Wafer	3"	260038TRK
600		4"	260048TRK
600		6"	260068TRK
600		8"	260088TRK
600		10"	260108TRK
600		12"	260128TRK

**TABLE 9. FIRE SAFE SEATED REPAIR KIT PART NUMBER LIST**

ANSI Class	Valve Type	Valve Size	RTFM Repair Kit P/N	Metal Seat P/N
150	Lug	2"	215L022FRK	CX04699
150/300	Wafer		215W02FRK	
150	Lug	2.5"	215L252FRK	CX04700
150/300	Wafer		215W252FRK	
150	Lug	3"	215L032FRK	CX04701
150/300	Wafer		215W032FRK	
150	Lug	4"	215L042FRK	CX04702
150/300	Wafer		215W042FRK	
150	Lug	5"	215L052FRK	CX04718
150/300	Wafer		215W052FRK	
150	Lug	6"	215L062FRK	CX04703
150	Wafer		215W062FRK	
150	Lug	8"	215L082FRK	CX04705
150	Wafer		215W082FRK	
150	Lug	10"	215L102FRK	CX04707
150	Wafer		215W102FRK	
150	Lug	12"	215L122FRK	CX04709
150	Wafer		215W122FRK	
150	Lug	14"	215L142FRK	CX04721
150	Wafer		215W142FRK	
150	Lug	16"	215L162FRK	CX04723
150	Wafer		215W162FRK	
150	Lug	18"	215L182FRK	CX04725
150	Wafer		215W182FRK	
150	Lug	20"	215L202FRK	CX04727
150	Wafer		215W202FRK	
150	Lug	24"	215L242FRK	CX04729
150	Wafer		215W242FRK	

\*Class 300 Wafer, 2"-5" valves use Class 150 Wafer repair kits.



ANSI Class	Valve Type	Valve Size	RTFM Repair Kit P/N	Metal Seat P/N
300	Lug	2"	230L022FRK	CX04699
300	Lug	2.5"	230L252FRK	CX04700
300	Lug	3"	230L032FRK	CX04701
300	Lug	4"	230L042FRK	CX04702
300	Lug	5"	230L052FRK	CX04718
300	Lug	6"	230L062FRK	CX04704
300	Wafer		230W062FRK	
300	Lug	8"	230L082FRK	CX04706
300	Wafer		230W082FRK	
300	Lug	10"	230L102FRK	CX04708
300	Wafer		230W102FRK	
300	Lug	12"	230L122FRK	CX04710
300	Wafer		230W122FRK	
300	Lug	14"	230L142FRK	CX04722
300	Wafer		230W142FRK	
300	Lug	16"	230L162FRK	CX04724
300	Wafer		230W162FRK	
300	Lug	18"	230L182FRK	CX04726
300	Wafer		230W182FRK	
300	Lug	20"	230L202FRK	CX04728
300	Wafer		230W202FRK	
300	Lug	24"	230L242FRK	CX04730
300	Wafer		230W242FRK	

\*Class 300 Wafer, 2"-5" valves use Class 150 Wafer repair kits.

ANSI Class	Valve Type	Valve Size	RTFM Repair Kit P/N	Metal Seat P/N
600	Lug	3"	260L032FRK	CX04711
600	Wafer		260W032FRK	
600	Lug	4"	260L042FRK	CX04712
600	Wafer		260W042FRK	
600	Lug	6"	260L062FRK	CX04713
600	Wafer		260W062FRK	
600	Lug	8"	260L082FRK	CX04715
600	Wafer		260W082FRK	
600	Lug	10"	260L102FRK	CX04716
600	Wafer		260W102FRK	
600	Lug	12"	260L122FRK	CX04717
600	Wafer		160W122FRK	

**TABLE 10. METAL SEATED REPAIR KIT PART NUMBER LIST**

ANSI Class	Valve Type	Valve Size	Metal Repair Kit P/N
150	Lug	2"	215L022MRK
150/300	Wafer		215W022MRK
150	Lug	2.5"	215L252MRK
150/300	Wafer		215W252MRK
150	Lug	3"	215L032MRK
150/300	Wafer		215W032MRK
150	Lug	4"	215L042MRK
150/300	Wafer		215W042MRK
150	Lug	5"	215L052MRK
150/300	Wafer		215W052MRK
150	Lug	6"	215L062MRK
150	Wafer		215W062MRK
150	Lug	8"	215L082MRK
150	Wafer		215W082MRK
150	Lug	10"	215L102MRK
150	Wafer		215W102MRK
150	Lug	12"	215L122MRK
150	Wafer		215W122MRK
150	Lug	14"	215L142MRK
150	Wafer		215W142MRK
150	Lug	16"	215L162MRK
150	Wafer		215W162MRK
150	Lug	18"	215L182MRK
150	Wafer		215W182MRK
150	Lug	20"	215L202MRK
150	Wafer		215W202MRK
150	Lug	24"	215L242MRK
150	Wafer		215W242MRK

\*Class 300 Wafer, 2"-5" valves use Class 150 Wafer repair kits.



ANSI Class	Valve Type	Valve Size	Metal Repair Kit P/N
300	Lug	2"	230L022MRK
300	Lug	2.5"	230L252MRK
300	Lug	3"	230L032MRK
300	Lug	4"	230L042MRK
300	Lug	5"	230L052MRK
300	Lug	6"	230L062MRK
300	Wafer		230W062MRK
300	Lug	8"	230L082MRK
300	Wafer		230W082MRK
300	Lug	10"	230L102MRK
300	Wafer		230W102MRK
300	Lug	12"	230L122MRK
300	Wafer		230W122MRK
300	Lug	14"	230L142MRK
300	Wafer		230W142MRK
300	Lug	16"	230L162MRK
300	Wafer		230W162MRK
300	Lug	18"	230L182MRK
300	Wafer		230W182MRK
300	Lug	20"	230L202MRK
300	Wafer		230W202MRK
300	Lug	24"	230L242MRK
300	Wafer		230L242MRK

\*Class 300 Wafer, 2"-5" valves use Class 150 Wafer repair kits.

ANSI Class	Valve Type	Valve Size	Metal Repair Kit P/N
600	Lug	3"	260L032MRK
600	Wafer		260W032MRK
600	Lug	4"	260L042MRK
600	Wafer		260W042MRK
600	Lug	6"	260L062MRK
600	Wafer		260W062MRK
600	Lug	8"	260L082MRK
600	Wafer		260W082MRK
600	Lug	10"	260L102MRK
600	Wafer		260W102MRK
600	Lug	12"	260L122MRK
600	Wafer		260W122MRK

**AMENDMENT REGISTER**

<b>Date</b>	<b>ECN</b>	<b>Rev.</b>	<b>Page</b>	<b>Description</b>	<b>Initiator</b>
6/17/2015	M14803	A	ALL	New Release	SAV
6/6/2016	M15430	B	ALL	Added metal seated valve info, and 30" & 36" soft seated valve info. Added new body, disc, and stem materials. Added metal seat and UHMWPE seat repair kit part numbers.	SAV
2/10/2017	M16304	C	5	Revised Page 5, added flange gasket installation information.	SAV
10/22/2020	M17717	D	7-8	Updated bolting chart based on vendor recommendations	TH