

7706 REDUCING COUPLING



For pressure rating, listing, and approval information, refer to data sheet or visit SHURJOINT website www.shurjoint.com for details or contact your SHURJOINT representatives.

The Model 7706 Reducing Coupling allows direct reduction on a piping run and eliminates the need for a concentric reducer and couplings. The specially designed rubber gasket prevents the smaller pipe from telescoping into the larger pipe during vertical installation. All 7706 couplings are comprised of two identical housing segments, EPDM rubber gasket and plated track bolts and nuts. Housing segments are supplied with our standard painted finishes, i.e. orange or RAL3000 red. Optional finishes such as hot dipped zinc galvanized and custom epoxy coatings are available.



7706 couplings should always be installed so that the coupling bolt pads make metal to metal contact.



The Model 7706 couplings must not be used with an end cap, as the end cap could be sucked into the pipe by the vacuum created when a system is being drained.



material specification

- **Housing:**
Ductile Iron to ASTM A536, Gr. 65-45-12, min. tensile strength 65,000 psi (448 MPa).
- **Surface Finish:**
Standard painted finishes in orange or RAL3000 red.
 - Hot dip zinc galvanized (Option)
 - Epoxy Coatings in RAL3000 red or other colors (Option).

- **Rubber Gasket:**
Grade E-pw EPDM (Color code: Double Green stripe) approved under NSF/ANSI 61 and NSF/ANSI 372 for potable water service to +180°F (+82°C). Also good for services for water with acid, water with chlorine or chloramines, deionized water, seawater and waste water, dilute acids, oil-free air and many chemicals.
Not recommended for petroleum oils, minerals oils, solvents and aromatic hydrocarbons.
Maximum Temperature Range: -30°F (-34°C) to +230°F (+110°C)*.
*EPDM seat for water services, not recommended for steam services unless valves or components are accessible for frequent replacement.
 - (Option) Grade "E" EPDM (Color code: Green stripe)
Good for cold & hot water up to +230°F (+110°C). Also good for services for water with acid, water with chlorine or chloramines, deionized water, seawater and waste water, dilute acids, oil-free air and many chemicals. Not recommended for petroleum oils, minerals oils, solvents and aromatic hydrocarbons.
Maximum Temperature Range: -30°F (-34°C) to +230°F (+110°C)*.
 - Other options: Grade "T" - Nitrile
Grade "O" - Fluoroelastomer.
Grade "L" - Silicone.
- **Bolts & Nuts:**
Heat treated carbon manganese steel track bolts to ASTM A449-83a (or A183 Gr. 2), minimum tensile strength 110,000 psi (758 MPa), Zinc electroplated, with heavy-duty hexagonal nuts to ASTM A563.

For additional details contact Shurjoint.

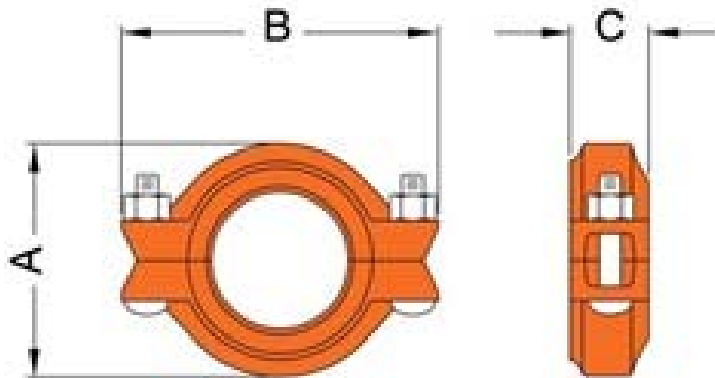

Model 7706 Reducing Coupling

Normal Size	Pipe O.D.	Max. Working Pressure (CWP)*	Max. End Load (CWP)	Axial Displacement†	Angular Movement***		Dimensions			Bolt Size	Weight
					Deg. Per Coupling	Per Pipe	A	B	C		
in	in	psi	lbf	in	(°)	in/ft	in	in	in	in	lbs
mm	mm	bar	kN	mm		mm/m	mm	mm	mm	mm	kg
1½ x 1¼	1.900 x 1.660	500	1410	0 - 0.065	1° - 54'	0.20	2.83	4.65	1.81	¾ x 2½	1.8
40 x 32	48.3 x 42.2	35	6.23	0 - 1.6		17	72	118	46	M10 x 55	0.8
2 x 1½	2.375 x 1.900	500	2210	0 - 0.065	1° - 31'	0.16	3.35	4.80	1.89	¾ x 2½	2.0
50 x 40	60.3 x 48.3	35	9.70	0 - 1.6		13	85	122	48	M10 x 55	0.9
2½ x 2	2.875 x 2.375	500	3240	0 - 0.065	1° - 15'	0.13	3.78	5.67	1.89	¾ x 2½	2.6
65 x 50	73.0 x 60.3	35	14.22	0 - 1.6		11	96	144	48	M10 x 55	1.2
76.1 x 50	3.000 x 2.375	500	3530	0 - 0.065	1° - 12'	0.13	4.02	5.67	1.89	¾ x 2½	2.6
	76.1 x 60.3	35	15.46	0 - 1.6		11	102	144	48	M10 x 55	1.2
3 x 2	3.500 x 2.375	500	4800	0 - 0.065	1° - 02'	0.11	4.57	6.61	1.89	½ x 3	3.3
80 x 50	88.9 x 60.3	35	21.09	0 - 1.6		9	116	168	48	M12 x 75	1.5
3 x 2½	3.500 x 2.875	500	4800	0 - 0.065	1° - 02'	0.11	4.57	6.61	1.89	½ x 3	3.7
80 x 65	88.9 x 73.0	35	21.09	0 - 1.6		9	116	168	48	M12 x 75	1.7
80 x 76.1	3.500 x 3.000	500	4800	0 - 0.065	1° - 02'	0.11	4.57	6.61	1.89	½ x 3	3.7
	88.9 x 76.1	35	21.09	0 - 1.6		9	116	168	48	M12 x 75	1.7
4 x 2	4.500 x 2.375	500	7940	0 - 0.095	1° - 12'	0.13	5.75	7.80	1.93	½ x 3	5.3
100 x 50	114.3 x 60.3	35	34.87	0 - 2.4		11	146	198	49	M12 x 75	2.4
4 x 2½	4.500 x 2.875	500	7940	0 - 0.095	1° - 12'	0.13	5.75	7.80	1.93	½ x 3	5.7
100 x 65	114.3 x 73.0	35	34.87	0 - 2.4		11	146	198	49	M12 x 75	2.6
100 x 76.1	4.500 x 3.000	500	7940	0 - 0.095	1° - 12'	0.13	5.75	7.80	1.93	½ x 3	5.7
	114.3 x 76.1	35	34.87	0 - 2.4		11	146	198	49	M12 x 75	2.6
4 x 3	4.500 x 3.500	500	7940	0 - 0.095	1° - 12'	0.13	5.75	7.80	2.01	½ x 3	5.3
100 x 80	114.3 x 88.9	35	34.87	0 - 2.4		11	146	198	51	M12 x 75	2.4

7706 REDUCING COUPLING
Rev.20240927

Model 7706 Reducing Coupling												
Normal Size	Pipe O.D.	Max. Working Pressure (CWP)*	Max. End Load (CWP)	Axial Displacement†	Angular Movement***		Dimensions			Bolt Size	Weight	
					Deg. Per Coupling	Per Pipe	A	B	C			
					(°)	in/ft	in	in	in			in
in	in	psi	lbf	in	(°)	mm/m	mm	mm	mm	mm	mm	kg
139.7 x 100	5.500 x 4.500	400	9490	0 - 0.125	1° - 18'	0.14	6.30	9.45	2.01	5/8 x 3 1/2	8.4	
	139.7 x 114.3	28	42.90	0 - 3.2		12	160	240	51	M16 x 90	3.8	
5 x 4	5.563 x 4.500	400	9710	0 - 0.125	1° - 18'	0.14	6.30	9.84	2.01	5/8 x 3 1/2	7.9	
125 x 100	141.3 x 114.3	28	43.88	0 - 3.2		12	160	242	51	M16 x 90	3.6	
165.1 x 80	6.500 x 3.500	400	13260	0 - 0.125	1° - 07'	0.12	7.95	10.63	2.05	5/8 x 3 1/2	10.1	
	165.1 x 88.9	28	59.91	0 - 3.2		10	202	270	52	M16 x 90	4.6	
6 x 3	6.625 x 3.500	400	13780	0 - 0.125	1° - 06'	0.12	8.19	10.63	2.05	5/8 x 3 1/2	10.1	
150 x 80	168.3 x 88.9	28	62.26	0 - 3.2		10	208	270	52	M16 x 90	4.6	
165.1 x 100	6.500 x 4.500	400	13260	0 - 0.125	1° - 07'	0.12	7.95	10.67	2.05	5/8 x 3 1/2	9.9	
	165.1 x 114.3	28	59.91	0 - 3.2		10	202	271	52	M16 x 90	4.5	
6 x 4	6.625 x 4.500	400	13780	0 - 0.125	1° - 06'	0.12	8.19	10.63	2.05	5/8 x 3 1/2	9.9	
150 x 100	168.3 x 114.3	28	62.26	0 - 3.2		10	208	270	52	M16 x 90	4.5	
8 x 6	8.625 x 6.625	400	23350	0 - 0.125	0° - 50'	0.09	10.24	13.11	2.09	3/4 x 4 3/4	14.3	
200 x 150	219.1 x 168.3	28	105.51	0 - 3.2		8	260	333	53	M20 x 120	6.5	
200 x 165.1	8.625 x 6.500	400	23350	0 - 0.125	0° - 50'	0.09	10.24	13.11	2.20	3/4 x 4 3/4	14.3	
	219.1 x 165.1	28	105.51	0 - 3.2		8	260	333	56	M20 x 120	6.5	

* * Working Pressure is based on roll- or cut-grooved standard wall carbon steel pipe. Pressure ratings for use on cut grooved pipe, thin wall carbon steel pipe, and on stainless steel pipe can be found on Shurjoint publication [B-33](#).

† Allowable Axial Displacement and Angular Movement (deflection) figures are for roll grooved standard steel pipe. Values for cut grooved pipe will be double that of roll grooved. These values are maximums; for design and installation purposes these figures should be reduced by: 50% for 3/4" - 3 1/2"; 25% for 4" and larger to compensate for jobsite conditions.

** Deflection or angular movement given is the maximum value that a coupling allows. When using the given maximum angles for a curved layout, proper bracing should be used to counter pressure thrust that will occur when the system is pressurized.

Flexible couplings can be used for angular movement and or thermal expansion, though please note individual coupling(s) cannot be used to their maximums for both types of movement within a system at the same time.

The Model 7706-T Transition Coupling allows for a direction transition from IPS pipe sizes to ISO pipe sizes.

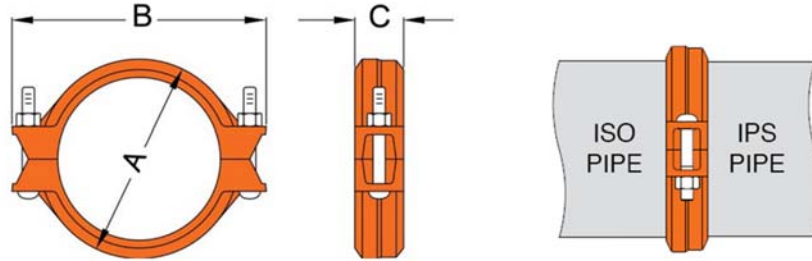

Model 7706-T Transition Coupling

Normal Size	Pipe O.D.	Max. Working Pressure (CWP)*	Max. End Load (CWP)	Axial Displacement†	Angular Movement***		Dimensions			Bolt Size	Weight
					Deg. Per Coupling	Per Pipe	A	B	C		
in	in	psi	lbf	in	(°)	in/ft	in	in	in	in	lbs
mm	mm	bar	kN	mm		mm/m	mm	mm	mm	mm	kg
2½ x 76.1	2.875 x 3.000	500	2110	0 - 0.065	1° - 12'	0.13	4.02	5.43	1.89	¾ x 2½	2.6
	73.0 x 76.1	35	9.09	0 - 1.6		11	102	138	48	M10 x 55	1.2
6 x 165.1	6.625 x 6.500	400	9940	0 - 0.125	0° - 33'	0.12	7.87	10.63	2.09	⅝ x 3½	7.7
	168.3 x 165.1	28	42.80	0 - 3.2		10	200	270	53	M16 x 90	3.5

*Working Pressure is based on roll grooved standard wall carbon steel pipe.

†Allowable Axial Displacement and Angular Movement (deflection) figures are for roll grooved standard steel pipe. Values for cut grooved pipe will be double that of roll grooved. These values are maximums; for design and installation purposes these figures should be reduced by 50% for ¾" - 3½"; 25% for 4" and larger to compensate for jobsite conditions.

** Deflection or angular movement given is the maximum value that a coupling allows. When using the given maximum angles for a curved layout, proper bracing should be used to counter pressure thrust that will occur when the system is pressurized. Flexible couplings can be used for angular movement and or thermal expansion, though please note individual coupling(s) cannot be used to their maximums for both types of movement within a system at the same time.

The pressure drop or head loss across Model 7706 Reducing Coupling is small and less than that of the same size of concentric reducer. Equivalent lengths of sch. 40 steel pipe (new pipe) for water 60°F (16°C) are shown in the table.

Model 7706 Reducing Coupling			
Size	Equivalent Length	Size	Equivalent Length
in	feet	in	feet
mm	m	mm	m
1½ x 1¼	1.6	4 x 2½	4.9
40 x 32	0.5	100 x 65	1.5
2 x 1	3.9	4 x 3	3.6
50 x 25	1.2	100 x 80	1.1
2 x 1½	2	5 x 4	3
50 x 40	0.6	125 x 100	0.9
2½ x 2	2	6 x 3	7.9
65 x 50	0.6	150 x 80	2.4
3 x 2	3.9	6 x 4	5.9
80 x 50	1.2	150 x 100	1.8
3 x 2½	2.3	6 x 5	4.5
80 x 65	0.7	150 x 125	1.37
4 x 2	6.2	8 x 6	7.2
100 x 50	1.9	200 x 150	2.2

General note

- Maximum Working Pressure (CWP) listed is the maximum cold-water pressure for general piping services tested to ASTM F1476 and or AWWA C606 methods. Figures listed are based on roll- or cut-grooved standard wall carbon steel pipe. For other pipe schedules or pipe materials, contact Shurjoint for additional information.
- Max. End Load is calculated based on the maximum working pressure (CWP).
- Listed and or Approved Pressures are pressure ratings for fire protection systems, tested and approved by various approval bodies. Please always refer to the latest approval data posted on the Shurjoint website.
- Field Joint Test: For one time only, the system may be tested hydrostatically at 1½ times the maximum working pressure listed (AWWA C606 5.2.3).
- Warning: Piping systems must always be depressurized and drained before attempting disassembly and or removal of any components.
- The 10 Year Limited Warranty applies to manufacturing defects only and does not cover severe service/temperature applications or wear parts.
- Shurjoint reserves the right to change specifications, designs and or standard without notice and without incurring any obligations.