

7707N HEAVY DUTY FLEXIBLE COUPLING



For pressure rating, listing, and approval information, refer to data sheet or visit SHURJOINT website www.shurjoint.com for details or contact your SHURJOINT representatives.

The Model 7707N Heavy Duty Flexible Coupling is designed for use in a variety of general piping applications of moderate or high pressure services. The Model 7707N couplings feature flexibility that can deal with misalignment, distortion, thermal stress, vibration and noise, and can also resist seismic tremors. With the use of Model 7707N couplings you can even design a curved layout. See Typical application – Flexible Couplings for more details.

The Model 7707N couplings sizes 14" – 26" (350 mm – 650 mm) are comprised of two identical ductile iron housing segments, an EPDM rubber gasket, and one or two bolts at each segment joint to ensure a positive connection and seal.



7707N couplings should always be installed so that the coupling bolt pads make metal to metal contact.

material specification

- **Housing:**
Ductile Iron to ASTM A536, Gr. 65-45-12, min. tensile strength 65,000 psi (448 MPa).
- **Surface Finish:**
Standard painted finishes in orange.
 - Hot dip zinc galvanized (option).
 For additional details contact Shurjoint.

- **Rubber Gasket:**
Grade E-pw EPDM (Color code: Double Green stripe) approved under NSF/ANSI 61 and NSF/ANSI 372 for potable water service to +180°F (+82°C). Also good for services for water with acid, water with chlorine, deionized water, seawater and waste water, dilute acids, oil-free air and many chemicals.
Not recommended for petroleum oils, minerals oils, solvents and aromatic hydrocarbons.
Maximum Temperature Range: -30°F (-34°C) to +230°F (+110°C)*.
*EPDM seat for water services are not recommended for steam services unless valves or components are accessible for frequent replacement.
 - Other options: Grade "E" - EPDM
Grade "T" - Nitrile
Grade "O" - Fluoroelastomer.
Grade "L" - Silicone.
 For additional details contact Shurjoint.
- **Bolts & Nuts:**
Heat treated carbon manganese steel track bolts to ASTM A449-83a (or A183 Gr. 2), minimum tensile strength 110,000 psi (758 MPa), Zinc electroplated, with heavy-duty hexagonal nuts to ASTM A563. Plain washers are always supplied for epoxy coated couplings.
 - Type 304 or 316 track bolts with heavy duty nuts (optional), Please check with Shurjoint customers service for availability

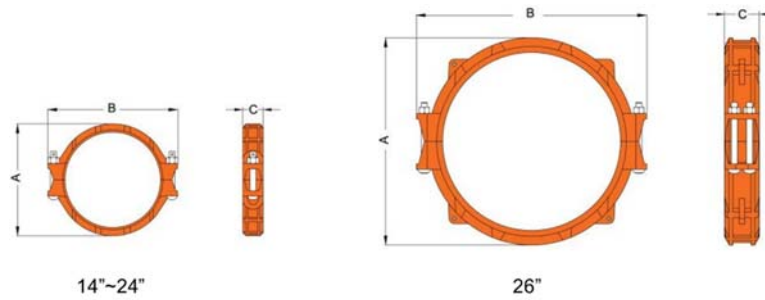

Model 7707N Heavy Duty Flexible Coupling

Normal Size	Pipe O.D.	Max. Working Pressure (CWP)*	Max. End Load (CWP)	Axial Displacement†	Angular Movement***		Dimensions			Bolt		Weight
					Deg. Per Coupling	Per Pipe	A	B	C	No.	Size	
in	in	psi	lbf	in	(°)	in/ft	in	in	in		in	lbs
mm	mm	bar	kN	mm		mm/m	mm	mm	mm			kg
14	14.00	300	46150	0.125	0° - 31'	0.11	16.23	19.80	2.95	2	7/8 x 6 1/2	34.5
350	355.6	20	198.53	3.2		9.0	412.0	503.0	75.0			15.7
16	16.00	300	60280	0.125	0° - 27'	0.09	18.23	21.85	2.95	2	1 x 6 1/2	37.0
400	406.4	20	259.30	3.2		7.9	463.0	555.0	75.0			16.8
18	18.00	300	76300	0.125	0° - 24'	0.08	20.45	24.06	3.11	2	1 x 6 1/2	47.1
450	457.2	20	327.89	3.2		7.0	520.0	611.0	79.0			22.3
20	20.00	300	94200	0.125	0° - 22'	0.07	22.48	26.38	3.11	2	1 x 6 1/2	54.4
500	508.0	20	405.16	3.2		6.3	571.0	670.0	79.0			24.7
22	22.00	300	113980	0.125	0° - 19'	0.07	24.46	30.16	3.11	2	1 1/8 x 6 1/2	63.0
550	558.8	20	490.60	3.2		5.7	621.4	766.0	79.0			28.6
24	24.00	300	135640	0.125	0° - 18'	0.06	26.55	30.43	3.11	2	1 1/8 x 6 1/2	65.1
600	609.6	20	584.20	3.2		5.3	674.0	773.0	79.0			29.5
26	26.00	300	159190	0.125	0° - 17'	0.06	29.68	33.15	4.94	4	7/8 x 9 5/8	143.0
650	660.4	20	684.72	3.2		4.9	754.0	842.0	125.6			65.0

*Working Pressure is based on roll grooved standard wall carbon steel pipe. Pressure ratings for use on cut grooved XS steel pipe and roll grooved light wall steel pipe can be found on Shurjoint publication [B-33](#).

† Allowable Axial Displacement and Angular Movement (deflection) figures are for roll grooved standard steel pipe. Values for cut grooved pipe will be double that of roll grooved. These values are maximums; for design and installation purposes these figures should be reduced by 50% for 3/4" - 3 1/2"; 25% for 4" and larger to compensate for jobsite conditions.

** Deflection or angular movement given is the maximum value that a coupling allows. When using the given maximum angles for a curved layout, proper bracing should be used to counter pressure thrust that will occur when the system is pressurized.

Flexible couplings can be used for angular movement and or thermal expansion, though please note individual coupling(s) cannot be used to their maximums for both types of movement within a system at the same time.

General note

- Maximum Working Pressure (CWP) listed is the maximum cold water pressure for general piping services tested to ASTM F1476 and or AWWA C606 methods. Figures listed are based on roll- or cut-grooved standard wall carbon steel pipe. For other pipe schedules or pipe materials, contact Shurjoint for additional information.
- Max. End Load is calculated based on the maximum working pressure (CWP).
- Listed and or Approved Pressures are pressure ratings for fire protection systems, tested and approved by various approval bodies. Please always refer to the latest approval data posted on the Shurjoint website.
- Field Joint Test: For one time only, the system may be tested hydrostatically at 1½ times the maximum working pressure listed (AWWA C606 5.2.3).
- Warning: Piping systems must always be depressurized and drained before attempting disassembly and or removal of any components.
- The 10 Year Limited Warranty applies to manufacturing defects only and does not cover severe service/temperature applications or wear parts.
- Shurjoint reserves the right to change specifications, designs and or standard without notice and without incurring any obligations.

Aalberts integrated piping systems APAC Inc.

11F-2 No. 175 Zhongzheng 2nd Rd. / Lingya, Kaohsiung

Taiwan

www.aalberts.com/ips