

## SJ-200 LOW-PROFILE BUTTERFLY VALVE



The Shurjoint Model SJ-200 Butterfly Valve is a low profile, grooved-end butterfly valve for oil & gas and or mining services. Working pressure is rated up to 232 psi / 1600 kPa and service temperatures up to +180°F/+82°C (Nitrile body liner). The Model SJ-200 features a fully rubber lined body with 316 stainless steel disc. The end-to-end dimensions conform to MSS SP-67. The lever handle is equipped with a tamper resistant locking device.

For pressure rating, listing, and approval information, refer to data sheet or visit SHURJOINT website [www.shurjoint.com](http://www.shurjoint.com) for details or contact your SHURJOINT representatives.

### material specification

- **Valve Body:**  
Ductile Iron to ASTM A536, Gr. 65-45-12, min tensile strength 65,000 psi (448 MPa).
- **Discs:**  
Stainless Steel CF8M (316).
- **Valve Body Coating:**  
Epoxy paint, black.
- **Valve Body Liner:**  
Grade "T" Nitrile (color code: Orange stripe)  
Recommended for petroleum products, vegetable oils, mineral oils and air with oil vapors. Temperature range: -20°F to +180°F (-29°C to +82°C). Also good for water services under +150°F (+66°C).  
Do not use for HOT WATER above +150°F (+66°C) or HOT DRY AIR above +140°F (+60°C)
- **Upper & Lower Shafts:**  
Stainless steel Type 416.
- **O-ring:**  
NBR
- **Nut:**  
Carbon steel nylon lock nut, zinc electro plated.
- **Lever Handle:**  
Carbon steel, zinc electro plated with plastic grip.

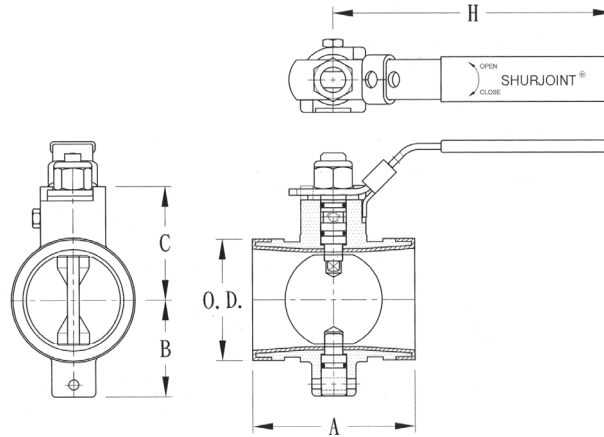

Model SJ-200 Low-Profile Butterfly Valve

Nom. Size	Pipe O.D.	Max. Working Pressure (CWP)*	Dimensions				Weight
			A	B	C	H	
in	in	PSI	in	in	in	in	lbs
mm	mm	Bar	mm	mm	mm	mm	kg
2	2.375	232	3.19	1.89	2.25	5.51	2.0
50	60.3	16	81	48	57	140	0.9
2½	2.875	232	3.82	2.13	2.65	7.48	3.3
65	73.0	16	97	54	67	190	1.5
3	3.500	232	3.82	2.44	2.94	7.48	4.2
80	88.9	16	97	62	75	190	1.9
4	4.500	232	4.57	3.00	4.19	10.79	8.6
100	114.3	16	116	76	106.3	274	3.9
6	6.625	232	5.83	4.09	5.45	10.79	22.2
150	168.3	16	148	104	138.5	274	10.1
8	8.625	232	5.25	5.50	6.45	10.79	27.9
200	219.1	16	133	140	163.9	274	11.3

\*Working pressure is based on connection with roll- or cut-grooved standard wall carbon steel pipe.

General note

- Maximum Working Pressure (CWP) listed is the maximum cold water pressure for general piping services tested to ASTM F1476 and or AWWA C606 methods. Figures listed are based on roll- or cut-grooved standard wall carbon steel pipe. For other pipe schedules or pipe materials, contact Shurjoint for additional information.
- Field Joint Test: For one time only, the system may be tested hydrostatically at 1½ times the maximum working pressure listed (AWWA C606 5.2.3).
- Warning: Piping systems must always be depressurized and drained before attempting disassembly and or removal of any components.
- The 10 Year Limited Warranty applies to manufacturing defects only and does not cover severe service/temperature applications or wear parts.
- Shurjoint reserves the right to change specifications, designs and or standard without notice and without incurring any obligations.