

C305 RIGID COUPLING FOR CTS



For pressure rating, listing, and approval information, refer to data sheet or visit SHURJOINT website www.shurjoint.com for details or contact your SHURJOINT representatives.

The Model C305 Rigid Coupling is ideal for joining copper tubing (CTS) in sizes 2" - 6". The C305 provides a fast, easy, economical and durable method of joining copper tubing without the use of heat or lead. The C305 features an angle pad design for a rigid joint and easy swing-over installation. The C305 features a pressure responsive EPDM GapSeal gasket which seals both the outside of the tubing and the gap between the tubing ends isolating the fluid from coupling housings. The C305 is rated up to 300 psi (20 bar), depending on the type and size of copper tubing used.

Applicable copper tubing:

- 1) ASTM B-88 Type K, Type L, and Type M Seamless copper water tube.
- 2) ASTM B306 Copper Drainage Tuber (DWV).
- 3) BS EN 1057 copper tubing.
- 4) AS1432 Type A, Type B and Type D Copper tubing.



C305 couplings should always be installed so that the coupling bolt pads make metal to metal contact.



Roll Set

As copper tubing is thinner than carbon steel pipe, always use a roll set specifically designed for use on copper tubing.

material specification

- **Housing:**
Ductile Iron to ASTM A536, Gr. 65-45-12, min. tensile strength 65,000 psi (448MPa).
- **Surface Finish:**
Epoxy coated in copper color.
- **Rubber Gasket:**
Grade E-pw EPDM (Color code: Double Green stripe) certified under NSF/ANSI 61 and NSF/ANSI 372 for potable water service to +180°F (+82°C). Also good for services for water with acid, water with chlorine or chloramines, deionized water, seawater and waste water, dilute acids, oil-free air and many chemicals.
Maximum Temperature Range: -30°F (-34°C) to +230°F (+110°C).
- **Bolts & Nuts:**
Heat treated carbon manganese steel track bolts to ASTM A449-83a (or A183 Gr. 2), minimum tensile strength 110,000 psi (758 MPa), Zinc electroplated, with heavy-duty hexagonal nuts to ASTM A563.

For additional details contact Shurjoint.

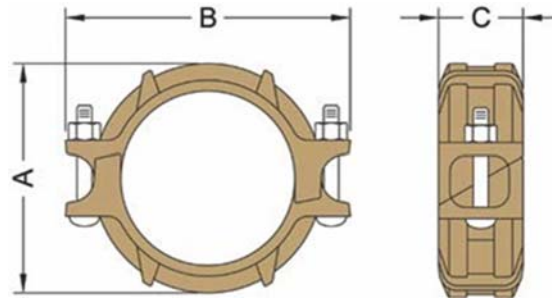

TYPE K, L, M (ASTM B-88) & TYPE DWV (ASTM B306)

Model C305 Rigid Coupling For Copper Tubing

Nominal Size	Pipe O.D.	Max. Working Pressure (CWP)*	Max. End Load (CWP)	Pipe End Separation	Dimensions			Bolts Size	Weight
					A	B	C		
in	in	PSI	lbs	in	in	in	in	lbs	
mm	mm	Bar	kN	mm	mm	mm	mm	kg	
2	2.125	300	1060	0.06	3.17	4.63	1.89	$\frac{3}{8} \times 2\frac{1}{8}$	1.8
50	54.0	20	4.58	1.5	81	118	48	$\frac{3}{8} \times 2\frac{1}{8}$	0.8
2½	2.625	300	1620	0.06	3.66	5.28	1.89	$\frac{3}{8} \times 2\frac{1}{8}$	2.0
65	66.7	20	6.98	1.5	93	134	48	$\frac{3}{8} \times 2\frac{1}{8}$	0.9
3	3.125	300	2290	0.06	4.21	6.06	1.89	$\frac{1}{2} \times 3$	2.8
80	79.4	20	9.90	1.5	107	154	48	$\frac{1}{2} \times 3$	1.3
4	4.125	300	4000	0.06	5.20	7.28	1.89	$\frac{1}{2} \times 3$	3.5
100	104.8	20	17.24	1.5	132	185	48	$\frac{1}{2} \times 3$	1.6
5	5.125	300	6180	0.06	6.26	8.66	1.89	$\frac{5}{8} \times 3\frac{1}{2}$	4.6
125	130.2	20	26.61	1.5	159	220	48	$\frac{5}{8} \times 3\frac{1}{2}$	2.2
6	6.125	300	8830	0.06	7.24	9.76	1.89	$\frac{5}{8} \times 3\frac{1}{2}$	5.5
150	155.6	20	38.01	1.5	184	248	48	$\frac{5}{8} \times 3\frac{1}{2}$	2.5

*Working pressure is for connection with roll-grooved Type K copper tubing. Pressure ratings for use on Type L, Type M, and Type DWV copper tubing can be found on Shurjoint publication [B-43](#).

Notes / Options: Couplings with rubber gaskets are likely to function as an insulator. Where electrical continuity is required, the Shurjoint Model 96 Continuity Clip will restore electrical continuity to the system. The continuity clip satisfies IEE Wiring Regulations.

BS EN 1057

Model C305 Rigid Coupling For Copper Tubing

Nominal Size	Pipe O.D.	Max. Working Pressure (CWP)*	Dimensions			Bolt / Nut Size	Weight
			A	B	C		
mm	mm	mm	mm	mm	mm	mm	kg
50	54.0	1.5	81	118	48	M10 x 55	0.8
65	66.7	1.5	93	134	48	M10 x 55	0.9
80	76.1	1.5	104	136	48	M10 x 55	1.3
100	108.0	3.2	138	176	48	M12 x 75	1.6
125	133.0	3.2	165	220	48	M16 x 90	2.2
150	159.0	3.2	190	248	48	M16 x 90	2.5

COPPER TUBING ROLL GROOVE SPECIFICATIONS

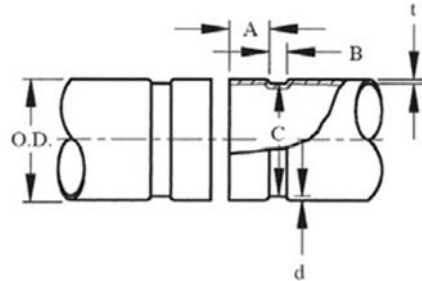

Type K, L, M (ASTM B-88) & Type DWV (ASTM B306)

1 Nominal Size	2 Pipe O.D. Basic Size	3 Gasket Seat A	4 Groove Width B	5 Groove Dia. C	6 Groove Depth (ref.) d	7 Min. Allowed Wall Thick. "t"	8 Max. Allowed Flare Dia.
		± 0.79	± 0.79	$+0/-0.51$			
		± 0.03	± 0.03	$+0/-0.02$			
in	in	in	in	in	in	in	in
mm	mm	mm	mm	mm	mm	mm	mm
2	2.125	0.610	0.300	2.029	0.048	0.064	2.220
50	54.0	15.5	7.6	51.5	1.2	1.6	56.4
2½	2.625	0.610	0.300	2.525	0.050	0.065	2.720
65	66.7	15.5	7.6	64.1	1.3	1.7	69.1
3	3.125	0.610	0.300	3.025	0.050	DWV	3.220
80	79.4	15.5	7.6	76.8	1.3		81.8
4	4.125	0.610	0.300	4.019	0.053	DWV	4.220
100	104.8	15.5	7.6	102.1	1.4		107.2
5	5.125	0.610	0.300	4.999	0.053	DWV	5.220
125	130.2	15.5	7.6	127.0	1.4		132.6
6	6.125	0.610	0.300	5.999	0.063	DWV	6.220
150	155.6	15.5	7.6	152.3	1.6		158.0

Nominal Size (Column 1): Nominal drawn copper tubing size.

Pipe O.D. (Column 2): Maximum allowable tolerances from square cut ends is 0.03" for 2" thru 3"; 0.045" for 4" thru 6"; and 0.060" for sizes 8".

Gasket Seating Surface (Column 3): The gasket seating surface shall be free from deep scores, marks, or ridges that would prevent a positive seal.

Groove Width (Column 4): Groove width is to be measured between vertical flanks of the groove side walls.

Groove Diameter (Column 5): The 'C' diameters are average values. The groove must be of uniform depth around the entire pipe circumference.

Groove Depth (Column 6): The 'd' is for reference use only. The groove dimension shall be determined by the groove diameter 'C'.

Minimum Wall Thickness (Column 7): The minimum wall thickness that may be roll grooved.

Flare Diameter (Column 8): The pipe end that may flare when the groove is rolled shall be within this limit when measured at the extreme end of the pipe.

C305 RIGID COUPLING FOR CTS
Rev. 2024.0927

BS EN 1057

1 Nominal Size	2 Pipe O.D.		3 Gasket Seat "A"	4 Groove Width "B"	5 Groove Dia. "C"	6 Groove Depth (ref.) "d"	8 Max. Allowed Flare Dia.
	Min.	Max.					
mm	mm	mm	mm	mm	mm	mm	mm
50	53.99	54.07	15.87	7.6	51.53	1.25	56.39
65	66.60	66.75	15.87	7.6	64.14	1.27	69.09
80	76.15	76.30	15.87	7.6	73.53	1.35	78.61
100	108.00	108.25	15.87	7.6	104.93	1.60	110.54
125	133.25	133.50	15.87	7.6	129.67	1.85	135.79
150	159.25	159.50	15.87	7.6	155.68	1.85	161.80

Nominal Size (Column 1): Nominal drawn copper tubing size.

Pipe O.D. (Column 2): Maximum allowable tolerances from square cut ends is 0.03" for 2" thru 3"; 0.045" for 4" thru 6"; and 0.060" for sizes 8".

Gasket Seating Surface (Column 3): The gasket seating surface shall be free from deep scores, marks, or ridges that would prevent a positive seal.

Groove Width (Column 4): Groove width is to be measured between vertical flanks of the groove side walls.

Groove Diameter (Column 5): The 'C' diameters are average values. The groove must be of uniform depth around the entire pipe circumference.

Groove Depth (Column 6): The 'd' is for reference use only. The groove dimension shall be determined by the groove diameter 'C'.

Minimum Wall Thickness (Column 7): The minimum wall thickness that may be roll grooved.

Flare Diameter (Column 8): The pipe end that may flare when the groove is rolled shall be within this limit when measured at the extreme end of the pipe.

General note

- Maximum Working Pressure (CWP) listed is the maximum cold water pressure for general piping services tested to ASTM F1476 and or AWWA C606 methods. Figures listed are based on roll- or cut-grooved standard wall carbon steel pipe. For other pipe schedules or pipe materials, contact Shurjoint for additional information.
- Max. End Load is calculated based on the maximum working pressure (CWP).
- Listed and or Approved Pressures are pressure ratings for fire protection systems, tested and approved by various approval bodies. Please always refer to the latest approval data posted on the Shurjoint website.
- Field Joint Test: For one time only, the system may be tested hydrostatically at 1½ times the maximum working pressure listed (AWWA C606 5.2.3).
- Warning: Piping systems must always be depressurized and drained before attempting disassembly and or removal of any components.
- The 10 Year Limited Warranty applies to manufacturing defects only and does not cover severe service/temperature applications or wear parts.
- Shurjoint reserves the right to change specifications, designs and or standard without notice and without incurring any obligations.